

QUIVOGNE

ROLLMOT / ROLLMAX

10m30

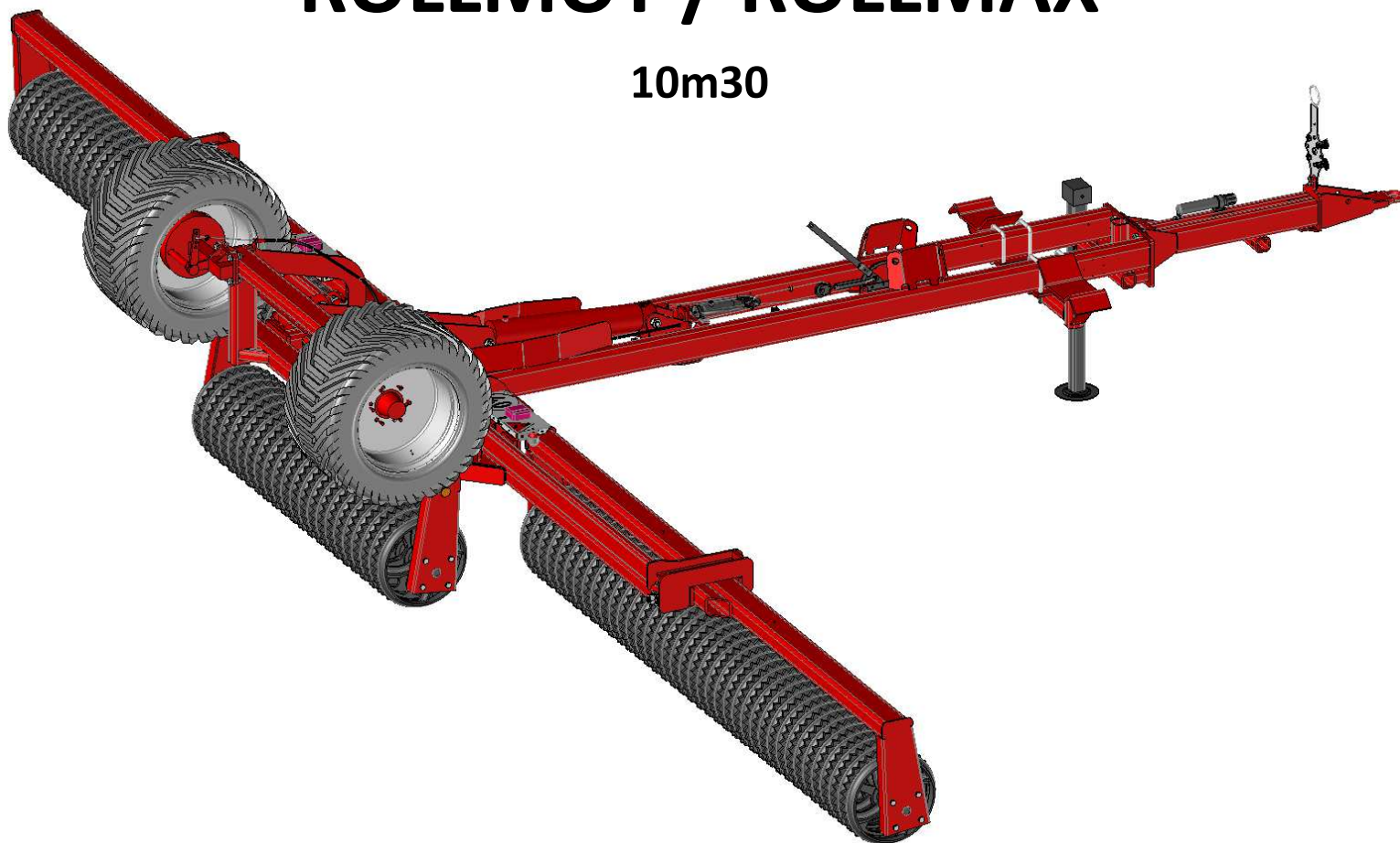

Catalogue pièces détachées Spare parts catalog Ersatzteilkatalog

Siège social et usine Z.I 70500 JUSSEY

Téléphone : 03.84.68.04.00

Télécopie : 03.84.92.26.59

E-mail : contact@quivogne.fr

06/2020

ROLLMOT - ROLLMAX 10m30

Planche N°1.1 : Flèches

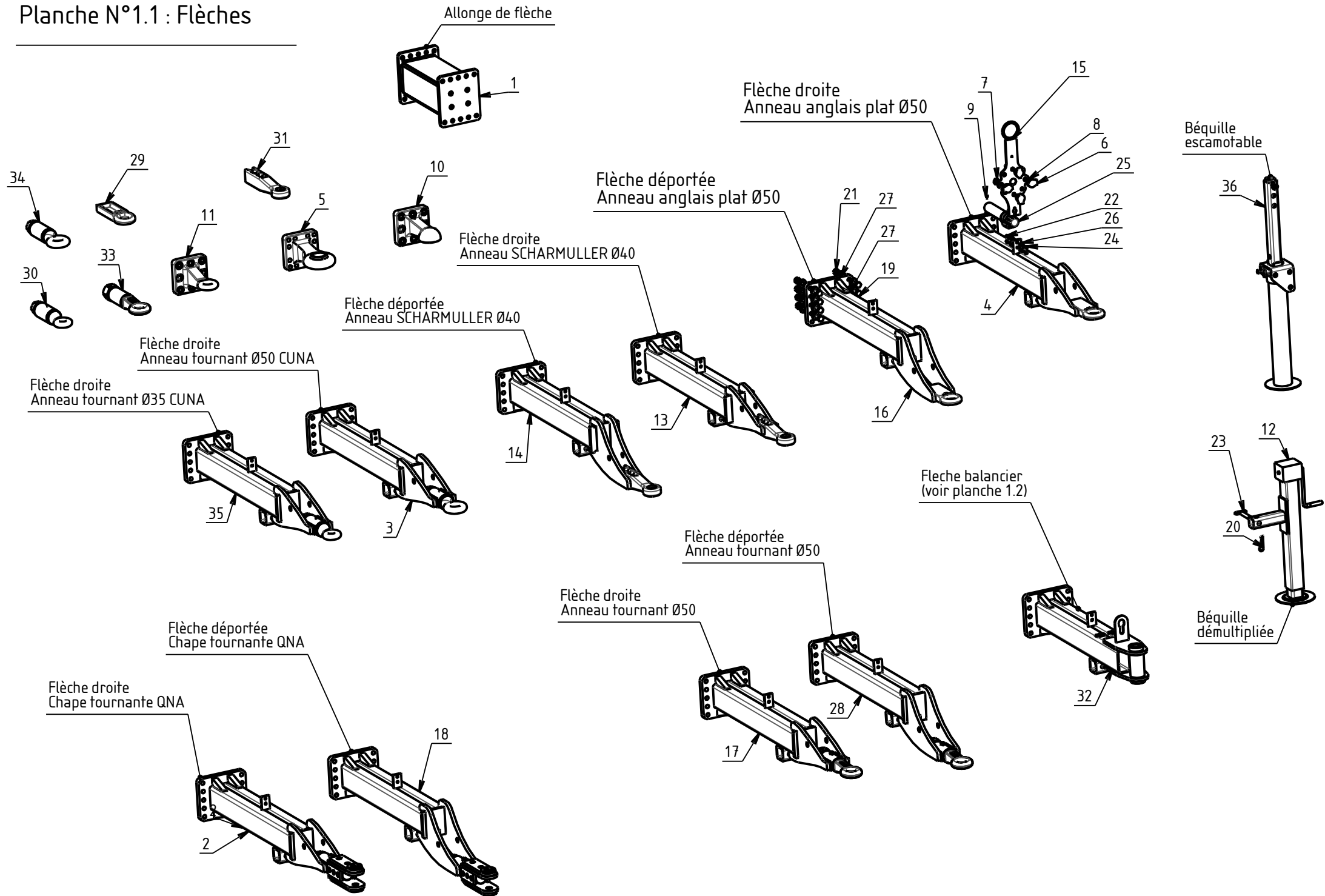

ROLLMOT/ ROLLMAX 10m30 (catalogue)

Rep.	Nom du produit	Beschreibung	Description	Designacion	Наименование	Code
1	Allonge de flèche lg 500/entraxe 245	Verlängerung/	Extension/			FLE00016
2	Flèche tube lg 1000 ROLLMOT &/RAP avec chape tour	Zugdeichsel/	Drawbar/	Lanza de enganche/		FLE00766
3	Flèche tube lg 1000 ROLLMOT &/RAP anneau tournan	Zugdeichsel/	Drawbar/	Lanza de enganche/		FLE00768
4	Flèche tube lg1000 ROLLMOT&RAP/entraxe 245 anne	Zugdeichsel/	Drawbar/	Lanza de enganche/		FLE00059
5	Anneau à boulonne cat.5 Ø71 mm/160x160 fixation 12	Zughöse Ø71 mm/	Ring Ø71 mm/	Argolla Ø71 mm/		ANN00041
6	Capuchon de coupleur/noir rigide pour HYD10720	Stopfen/	Plug/	Tapòn/	Колпачок муфты/	HYD00308
7	Support coupleur femelle/	Halter/	Bracket/	Soporte/		HYD10720
8	Support coupleur femelle/	Halter/	Bracket/	Soporte/		HYD10720
9	Vis T.H. 6x 10 Cl8.8 Zn/					VIS06042
10	Anneau boule K80 Calotte à/boulonner (entraxe 145x1	Zughöse/	Ball ring K80/	Argolla/		ANN00026
11	Anneau Ø50 SCHARMULLER/ Entraxe 145x145 8 trou	Zughöse/	Ring/	Argolla/		ANN00029
12	Bequille carré de 80 renvoi d'angle (démultipliée) de R	Ständer/	Stand/	Soporte/		BEQ08005
13	Flèche tube lg1000 ROLLMOT ent/245 Ann All Ø40 SC	Zugdeichsel/	Drawbar lg1000 Ø40 Schar	Lanza de enganche/		FLE00143
14	Flèche déport 155mm/entraxe 245 - anneau Allemand	Zugdeichsel/	Boom/	Lanza de enganche/		FLE00144
15	Support passe flexibles (8/flexibles) zn blanc 6 à 12 µm	Halter/	Bracket/	Soporte/		FLE00158
16	Flèche déport (155) entraxe/245 Rollmot/Rollmax 4m30	Zugdeichsel/	Boom/	Lanza de enganche/		FLE00195
17	Flèche tube lg 1000 ROLLMOT &/RAP anneau tournan	Zugdeichsel/	Drawbar/	Lanza de enganche/		FLE00765
18	Flèche déportée 155 ROLLMOT &/RAP avec chape tou	Zugdeichsel/	Drawbar/	Lanza de enganche/		FLE00776
19	Vis T.H. 20x 80 8.8 Zn/REPLACE PAR VIS20043	Schraube 20x80/	Screw 20x80/	Tornillo 20x80/	Болт Т.Н. 20x 80 8.8 Zn/	VIS20011
20	Goupille beta Ø4/	Stift beta Ø4/	Pin beta Ø4/	Pasador beta Ø4/	Штифт beta Ш4/	GOU04000
21	Ecrou nylstop M20 Zn/DIN 985	Mutter M20/	Nut M20/	Tuerca M20/	Гайка nylstop M20 Zn DIN 9	ECR20003
22	Ecrou nylstop M10 Zn/DIN 985 0871	Mutter M10/	Nut M10/	Tuerca M10/	Гайка nylstop M10 Zn/	ECR10002
23	Broche Ø20x105 BICHRIMATEE/	Spindel/	Pin/	Pasador/		BRO02015
24	Vis T.H. 10x 35 8.8 Zn/filetage total	Schraube/	Screw/	Tornillo/	Винт Т.Н.10x 35 8.8 Zn/	VIS10026
25	Porte document Noir Logo/Quivogne	Aktentasche/	briefcase/	maletín/	/	KHR00932
26	Rondelle plate 10L NFE25513/(Ø10.5/27 ep 2)	Scheibe/	Washer/	Arandela/		RON01099
27	Rondelle plate 20x45x2/	Scheibe 20x45x2/	Washer 20x45x2/	Arandela 20x45x2/		RON02002

ROLLMOT/ ROLLMAX 10m30 (catalogue)

Rep.	Nom du produit	Beschreibung	Description	Designacion	Наименование	Code
28	Flèche départ 155, entrax245/ann tournant Rollmot/Roll	Zugdeichsel/	Boom/	Lanza de enganche/		FLE00204
29	Anneau plat anglais - 20T/Oeil Ø50	Zughöse/	Ring/	Argolla/		ANN00002
30	Anneau tournant Ø35 CUNA/(Homologué E3) réf					ANN00043
31	Anneau all Ø40 dim 80x65x424/CH.VERT 2T CH.TRA		Ring Ø40 dim 80x65x424/ch			ANN00048
32	Flèche nue attelage balancier/TYPE D - ROLLMOT					FLE00733
33	Anneau tournant super lourd PT/50 NORME ISO PEIN	Zughöse/	Towing eye/	Argolla/	Кольцо /	ANN00003
34	Anneau tournant Ø50 CUNA/ITALIE (Homologué F2 18					ANN00040
35	Flèche tube lg 1000 ROLLMOT &/RAP anneau tournan	Zugdeichsel/	Drawbar/	Lanza de enganche/		FLE00767
36	Bequille escamotable complète/avec support (rollmot/r	Ständer/	Hydraulic stand with hand p	Soporte/	/	BEQ00204

Planche N°1.2 : ROLLMOT - ROLLMAX
Flèches balanciers CAT. 2 à 4)

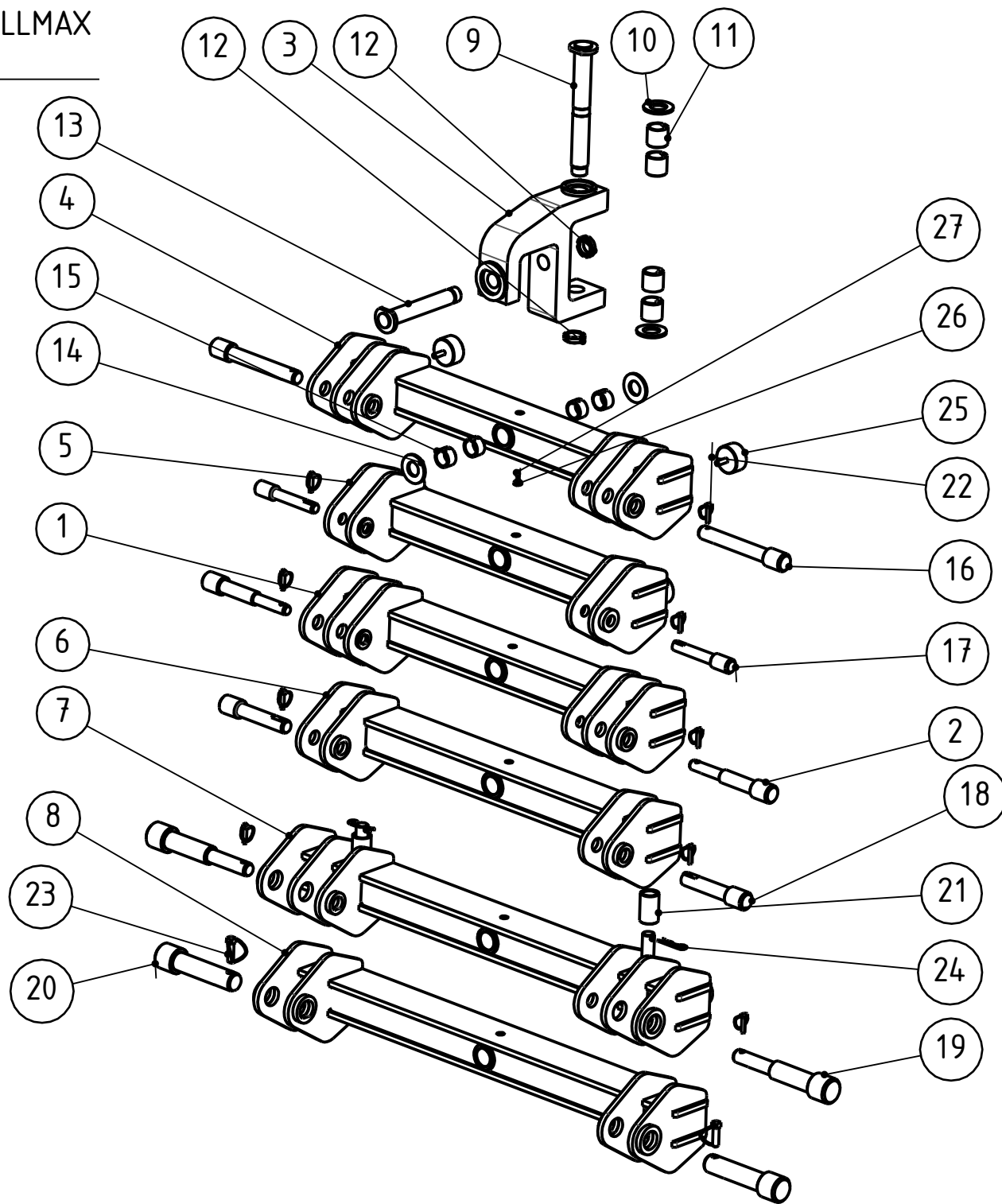

ROLLMOT/ROLLMAX 10m30 (catalogue)

Rep.	Nom du produit	Beschreibung	Description	Designacion	Наименование	Code
1	Pivot de balancier EA185/BLACKBEAR EVO	Drehzapfen/	Pivot/	Eje/		FLE00188
2	Pivot de balancier EA145/BLACKBEAR 6m30 & 8m10	Ausleger/	Beam/	Péndulo/		FLE00178
3	Croisillon d'attelage usiné/(pièce finie)	Gelenkkreuz/	Spider/	Cruceta/		FLE00184
4	Balancier flèche CAT.3 & 3N/BLACKBEAR	Ausleger/	Beam/	Péndulo/		FLE00190
5	Balancier flèche CAT.2/BLACKBEAR	Ausleger/	Beam/	Péndulo/		FLE00196
6	Balancier flèche CAT.3/BLACKBEAR	Ausleger/	Beam/	Péndulo/		FLE00185
7	Balancier flèche CAT.3 & 4/BLACKBEAR	Ausleger/	Beam/	Péndulo/		FLE00186
8	Balancier flèche CAT.4/BLACKBEAR	Ausleger/	Beam/	Péndulo/		FLE00187
9	Axe Ø 45x370 M40x1.5/traité arc cor v2355 (sous tête)	Achse/	Axle/	Eje/		AXE45054
10	Rondelle plate 45x80x6/	Scheibe/	Washer/	Arandela/	Плоская шайба 45x 80x 6/	RON04515
11	Bague Ø 45x 55 lg 50 CONNEX/	Büchse/	Bushing/	Casquillo/		BAG04510
12	Ecrou nylstop à encoches M40x1/,5 hauteur 16	Mutter/	Nut/	Tuerca/		ECR40005
13	Axe Ø 40x280 M40 x1.5/265 (sous tête) traité arc cor v2	Achse/	Axle/	Eje/		AXE40056
14	Rondelle plate 40x80x6/	Scheibe/	Washer/	Arandela/		RON04015
15	Bague Ø 40x 50 lg 30 CONNEX/	Büchse/	Bushing/	Casquillo/		BAG04008
16	Broche Ø36,5 lg 245 total 305/+ méplat cat.3 & 3N	Spindel/	Pin/	Pasador/		BRO36005
17	Broche Ø28x210/150 (sous tête) CAT.2	Spindel/	Pin/	Pasador/	Штырь Ш28x165/	BRO02815
18	Broche Ø36,5 lg 170 total 230/+ méplat N°3	Spindel/	Pin/	Pasador/		BRO36007
19	Broche Ø50/36 lg 350/(290/140 sous tete) CAT.3 & 4	Spindel/	Pin/	Pasador/		BRO50001
20	Broche Ø50 lg 207 total 267/+ méplat CAT.4	Achse/	Axle/	Eje/		BRO50002
21	Bague Ø 37,5x50.5 lg 80/balancier CAT.4	Büchse/	Bushing/	Casquillo/		BAG03703
22	Goupille clips Ø10/	Stift Ø10/	Pin Ø10/	Pasador Ø10/	Шплинт Ш 10/	GOU10000
23	Goupille clips Ø16 avec chaine/	Stift Ø 16/	Pin Ø 16/	Pasador Ø 16/	Шплинт Ш 16/	GOU16002
24	Goupille beta Ø4/	Stift beta Ø4/	Pin beta Ø4/	Pasador beta Ø4/	Штифт beta Ш4/	GOU04000
25	Support antivibrant/cylindrique Ø75 H40 M12x37	Stossdämpfer/	Shock absorber/	Amortiguador/	Антивибрационная цилиндр	SUP30500
26	Bouchon graissage ROUGE R3000/GPN 985/200	Stopfen/	Plug/	Tapòn/	Служная лрбка /	BOU00037
27	Graisseur M 8 droit/	Schmiernippel/	Grease nipple/	Engrasador/	Масленка М 8 лрямая/	GRA08001

Planche N°2 - ROLLMOT/ROLLMAX :
Chassis

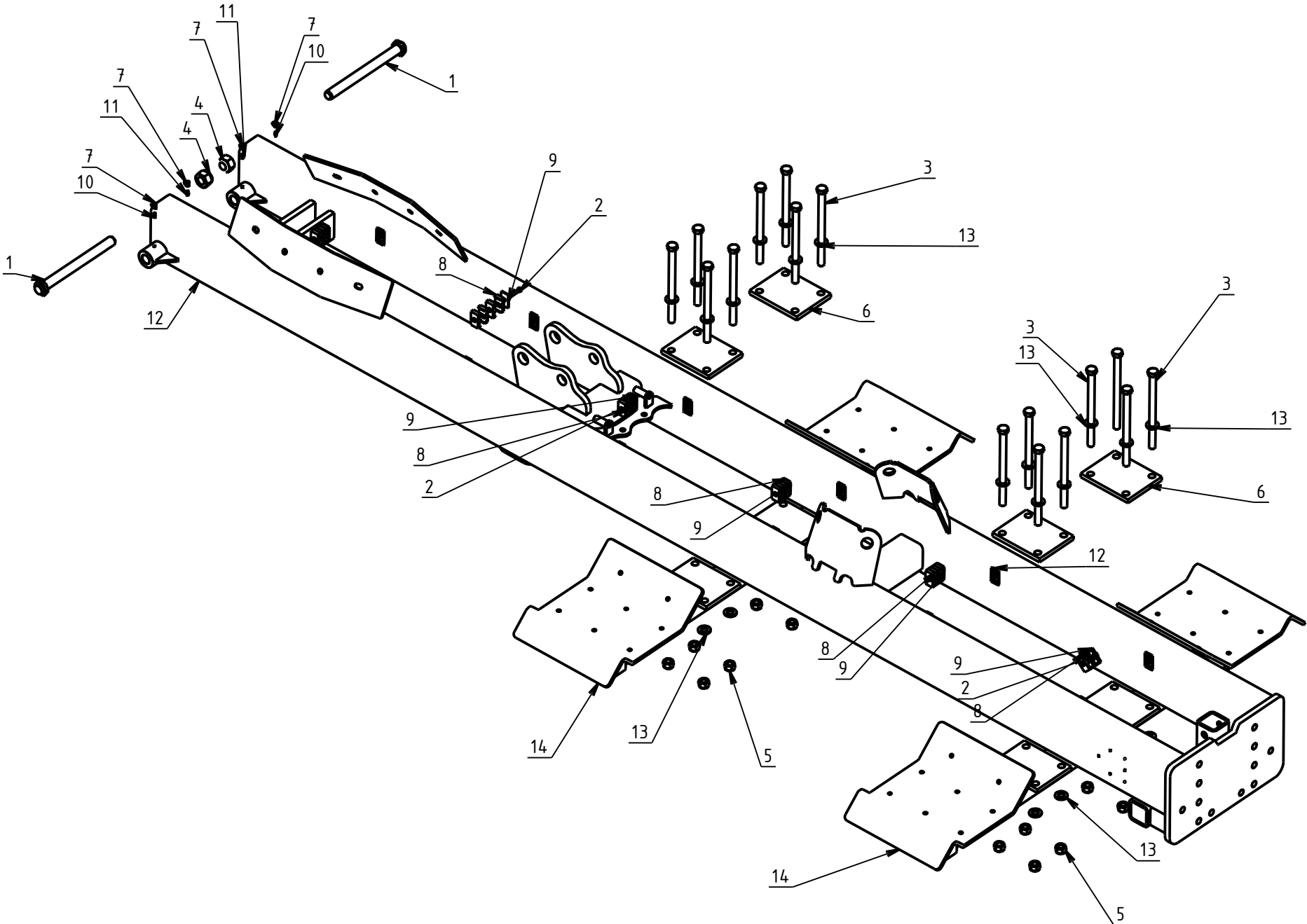

ROLLMOT/ROLLMAX 10m30 (catalogue)

Rep.	Nom du produit	Beschreibung	Description	Designacion	Наименование	Code
1	Axe Ø 30x330 M30 (acier)/(sous tête)	Achse/	Axle/	Eje/		AXE30069
2	Vis T.H. 8x 60 8,8 Zn/	Schraube 8x60/	Screw 8x60/	Tornillo 8x60/	Болт Т.Н. 8x 60 8,8 Zn/	VIS08026
3	Vis T.H. 20x290 8.8 Zn/	Schraube/	Screw/	Tornillo/	Болт Т.Н.20x290 8.8 Zn/	VIS20055
4	Ecrou nylstop M30 Zn/	Mutter M30/	Nut M30/	Tuerca M30/	Гайка nylstop M30 Zn/	ECR30002
5	Ecrou nylstop M20 Zn/DIN 985	Mutter M20/	Nut M20/	Tuerca M20/	Гайка nylstop M20 Zn DIN 9	ECR20003
6	Contre plaque de support avant/ROLLMOT/MAX	Platte/	Plate/	Placa/		RAP01249
7	Bouchon graissage ROUGE R3000/GPN 985/200	Stopfen/	Plug/	Tapòn/	Служкая лрбка /	BOU00037
8	Fixation 2 flexibles Ø16/partie plastique	Flexible Befestigung Ø16/	Flexible mounting Ø16/	Montaje flexible Ø16/		DIV00008
9	Fixation flexible partie/capuchon tole	Flexible Teile Befestigung	Flexible part mounting cap c	Tapa de montaje de la pieza		DIV00106
10	Graisseur M 6 droit auto/taraudeur	Schmiernippel/	Grease nipple/	Engrasador/		GRA06001
11	Graisseur M 8 droit/	Schmiernippel/	Grease nipple/	Engrasador/	Масленка М 8 лрямая/	GRA08001
12	Chassis ROLLMAX 10M30/	Rahmen/	Main frame/	Cajonera/		RAP01235
13	Rondelle plate 21x40x4 Zn/	Scheibe/	Washer/	Arandela/		RON02003
14	Support avant large de section/de Rollmot/Rollmax 10	Halter/	Bracket/	Soporte/		RAP01234

Planche N°3 : ROLLMOT / ROLLMAX
Chassis partie arrière

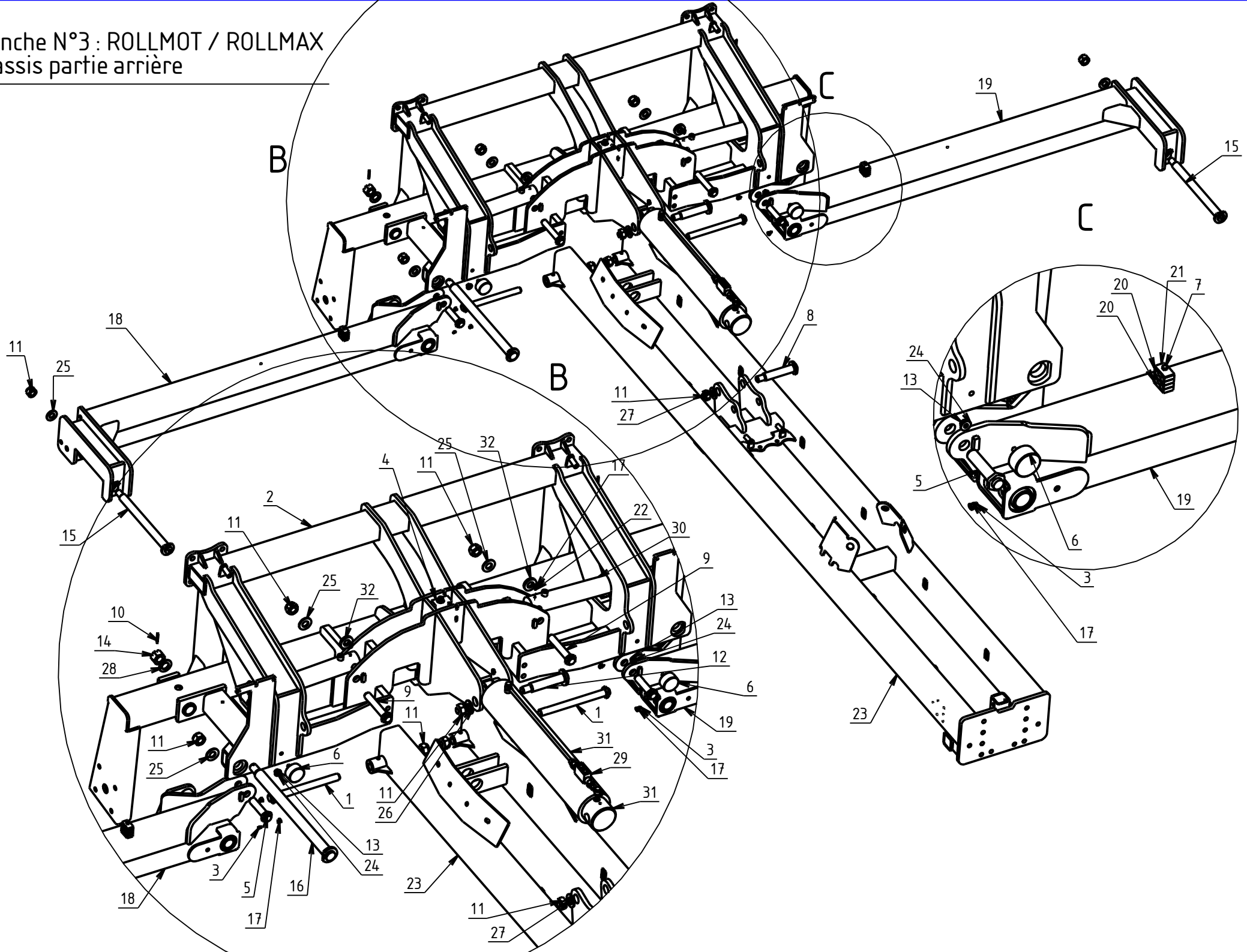

ROLLMOT/ROLLMAX 10m30 (catalogue)

Rep.	Nom du produit	Beschreibung	Description	Designacion	Наименование	Code
1	Axe Ø 30x330 M30 (acier)/(sous tête)	Achse/	Axle/	Eje/		AXE30069
2	Partie arrière ROLLMAX 10M30/bi-poutres 200x100	Rahmen/	Main frame/	Cajonera/		RAP01233
3	Graisseur M 8 droit/	Schmiernippel/	Grease nipple/	Engrasador/	Масленка М 8 лрямая/	GRA08001
4	Diviseur de débit entrée/1/2 G sortie 1/2 G (HYDAC)	Ausstoßteiler/	Flow divider/	divisor del flujo/	Делитель расхода/	HYD00021
5	Axe Ø 30x125 M30 (acier)/(sous tête)	Achse Ø30x125/	Axle Ø30x125/	Eje Ø30x125/		AXE30022
6	Support antivibrant/cylindrique Ø75 H40 M12x37	Stossdämpfer/	Shock absorber/	Amortiguador/	Антивибрационная цилиндр	SUP30500
7	Vis T.H. 8x 60 8,8 Zn/	Schraube 8x60/	Screw 8x60/	Tornillo 8x60/	Болт Т.Н. 8x 60 8,8 Zn/	VIS08026
8	Axe Ø 40x215 M30 (acier)/(sous tête)	Achse/	Axle/	Eje/		AXE40033
9	Axe Ø 30x170 (acier) (sous tête) tête rectangulaire	Achse/	Axle/	Eje/		AXE30014
10	Goupille mécanindus 6 x 50/épaisse DIN1481	Stift 6x50/	Pin 6x50/	Pasador 6x50/	Штифт 6x 50/	GOU06002
11	Ecrou nylstop M30 Zn/	Mutter M30/	Nut M30/	Tuerca M30/	Гайка nylstop M30 Zn/	ECR30002
12	Axe Ø 40x205 M30 (acier)/(sous tête)	Achse/	Axle/	Eje/		AXE40021
13	Ecrou nylstop M12 Zn/DIN 985	Mutter M12/	Nut M12/	Tuerca M12/	Гайка nylstop M12 Zn DIN 9	ECR12002
14	Ecrou creneaux HK M33x200/	Mutter M33x300/	Nut M33x300/	Tuerca M33x300/	Гайка M33x200/	ECR33006
15	Axe Ø 40x520 M30 (acier) (sous tête) graissage en bou	Achse Ø40x520/	Axle Ø40x520/	Eje Ø40x520/		AXE40075
16	Axe Ø 45x670 M33x200 sous tête/	Achse/	Axle/	Eje/		AXE45055
17	Bouchon graissage ROUGE R3000/GPN 985/200	Stopfen/	Plug/	Tapòn/	Слускная лробка /	BOU00037
18	Bras droit de ROLLMOT 1030/	Recht Kurbelarm/	Right crank/	Brazo derecha/		BRA00217
19	Bras gauche de ROLLMOT 1030/	Links Kurbelarm/	Left crank/	Brazo izquierda/		BRA00218
20	Fixation 2 flexibles Ø16/partie plastique	Flexible Befestigung Ø16/	Flexible mounting Ø16/	Montaje flexible Ø16/		DIV00008
21	Fixation flexible partie/capuchon tole	Flexible Teile Befestigung	Flexible part mounting cap c	Tapa de montaje de la pieza		DIV00106
22	Graisseur M 6 droit auto/tarauteur	Schmiernippel/	Grease nipple/	Engrasador/		GRA06001
23	Chassis ROLLMAX 10M30/	Rahmen/	Main frame/	Cajonera/		RAP01235
24	Rondelle plate 12x30x3 Zn/	Scheibe/	Washer/	Arandela/	Плоская шайба 12x30x3/	RON01202
25	Rondelle plate 30x60x5/	Scheibe/	Washer/	Arandela/	Плоская шайба 30x60x5/	RON03003
26	Rondelle plate 31x60x4 (Zn)/Zinguée blanc	Scheibe/	Washer/	Arandela/	Шайба ллоская 31x 60x 5/	RON03100
27	Rondelle plate 31x60x4 (Zn)/Zinguée blanc	Scheibe/	Washer/	Arandela/	Шайба ллоская 31x 60x 5/	RON03100

ROLLMOT/ROLLMAX 10m30 (catalogue)

Rep.	Nom du produit	Beschreibung	Description	Designacion	Наименование	Code
28	Rondelle plate 35x60x4/	Scheibe 35x60x4/	Washer 35x60x4/	Arandela 35x60x4/	Плоская шайба 35x60x4/	RON03502
29	Bloc hydraulique HV3/(ligne complète)	Gehäuse/	Case/	Casa/		VER00003
30	Vérin DE: 40x 70 C: 300 EF:510/A10033b réf 4073	Zylinder/	Cylinder/	Cilindro hidraulico/	Гидрочилиндр двойного дей	VER04011
31	Vérin DE: 60x140 C: 695 EF:945/trous Ø40,25 (des 2 c	Zylinder/	Cylinder/	Cilindro hidraulico/	Гидрочилиндр/	VER06014
32	Rondelle plate 30,5x60x10/	Scheibe/	Washer/	Arandela/		RON03008

Vue arrière bras de vérin

Planche N°4 : ROLLMOT / ROLLMAX Planche niveleuse

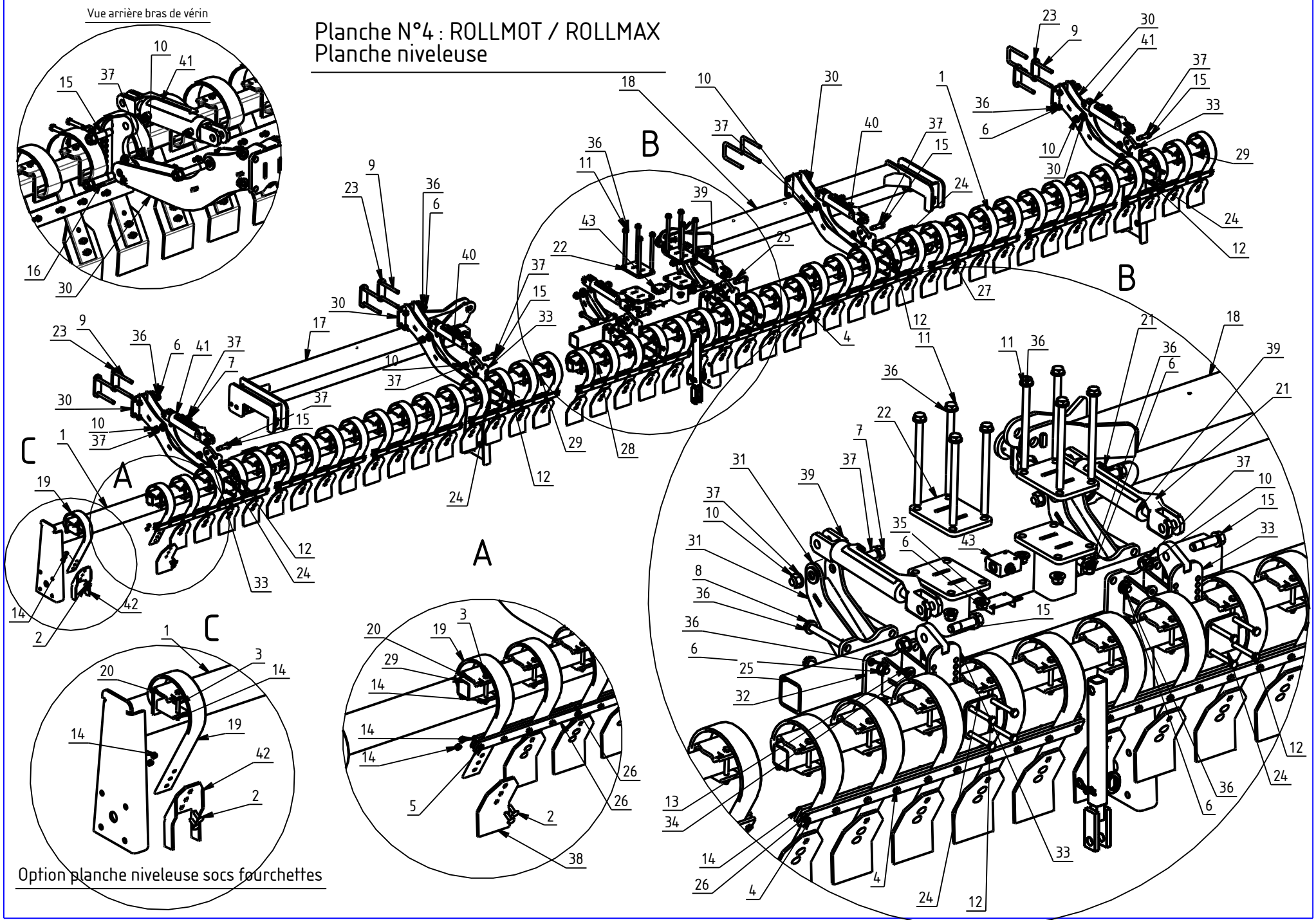

ROLLMOT/ROLLMAX 10m30 (catalogue)

Rep.	Nom du produit	Beschreibung	Description	Designacion	Наименование	Code
1	Section latérale Rollmax 10M30/tube lg 4200	Halter/	Bracket/	Soporte/		SEC00066
2	Vis T.R.C.C. 12x40 8.8/DIN603-8,8	Schraube/	Screw/	Tornillo/		VIS12086
3	Vis T.H. 12x110 8,8 Zn/	Schraube/	Screw/	Tornillo/		VIS12050
4	Vis T.H. 12x 45 8,8 Zn/filetage total	Schraube/	Screw/	Tornillo/		VIS12054
5	Vis T.H. 12x 45 8.8 Zn/	Schraube/	Screw/	Tornillo/		VIS12013
6	Ecrou nylstop M20 Zn/DIN 985	Mutter M20/	Nut M20/	Tuerca M20/	Гайка nylstop M20 Zn DIN 9	ECR20003
7	Boulon T.H.25x135 M24 (acier)/(sous tête)	Bolzen/	Bolt/	Perno/		BLS24047
8	Vis T.H. 20x160 8.8 Zn/	Schraube 20x160/	Screw 20x160/	Tornillo 20x160/	Винт Т.Н.20x160 8.8 Zn/	VIS20042
9	Vis T.H. 20x210 8.8 Zn/	Schraube 20x210/	Screw 20x210/	Tornillo 20x210/	Винт Т.Н.20x210 8.8 Zn/	VIS20053
10	Ecrou nylstop M24 Zn/	Mutter M24/	Nut M24/	Tuerca M24/	Гайка nylstop M24 Zn/	ECR24003
11	Vis T.H. 20x290 8.8 Zn/	Schraube/	Screw/	Tornillo/	Болт Т.Н.20x290 8.8 Zn/	VIS20055
12	Vis T.H. 14x110 8,8 Zn/	Schraube/	Screw/	Tornillo/	Болт Т.Н. 14x110 8,8 Zn/	VIS14039
13	Ecrou nylstop M14 Zn/	Mutter M14/	Nut M14/	Tuerca M14/	Гайка nylstop M14 Zn/	ECR14002
14	Ecrou nylstop M12 Zn/DIN 985	Mutter M12/	Nut M12/	Tuerca M12/	Гайка nylstop M12 Zn DIN 9	ECR12002
15	Boulon T.H.25x 95 M24 (acier)/(sous tête)	Achse/	Axle/	Eje/	Болт Т.Н.25x95 M24 (сталь)	BLS24013
16	Boulon T.H.25x120 M24 (acier)/(sous tête)	Bolzen/	Bolt/	Perno/		BLS24033
17	Bras droit de ROLLMOT 1030/	Recht Kurbelarm/	Right crank/	Brazo derecha/		BRA00217
18	Bras gauche de ROLLMOT 1030/	Links Kurbelarm/	Left crank/	Brazo izquierda/		BRA00218
19	Dent niveleuse 80x10 nue/ROLLMOT	Zinken/	Tine/	Diente/		DTS21150
20	Bride dent niveleuse 80x10/ROLLMOT 480107070	Bride/	Bridle/	Brida/		DTS21151
21	Coude M 12L - M G3/8 conique/	Ölanschluss/	Oil connector/	Empalme/	Колено наружное коническо	HYD10305
22	Contre plaque de support/planche niveleuse ROLLMOT	Platte/	Plate/	Placa/		RAP01248
23	Contre-plaque bras de pl.niv./pour ROLLMOT	Platte/	Plate/	Placa/		RAP01334
24	Contre-plaque de bielle de/réglage de pl.niv. de ROLL	Platte/	Plate/	Placa/		RAP01333
25	Barre support de bras planche/niveleuse central Ht = 1	Balken/	Bar/	Barra/		RAP01317
26	Plat de renfort dent de/planche niveleuse lg 1083	Platte/	Plate/	Placa/		RAP01320
27	Plat de renfort dent de/planche niveleuse lg 848	Platte/	Plate/	Placa/		RAP01321

ROLLMOT/ROLLMAX 10m30 (catalogue)

Rep.	Nom du produit	Beschreibung	Description	Designacion	Наименование	Code
28	Tube support de dent de pl.niv/10 dents - lg 2265	Tube/	Tube/	Tube/		RAP01341
29	Tube support de dent de pl.niv/17 dents - lg 3910	Tube/	Tube/	Tube/		RAP01345
30	Bras long pour verin de planch/niveleuse pour ROLLM	Kurbelarm/	Crank/	Brazo/		RAP01356
31	Support arrière bras court/planche niveleuse ROLLMO	Halter/	Bracket/	Soporte/		RAP01357
32	Support avant bras court/planche niveleuse ROLLMOT/	Halter/	Bracket/	Soporte/		RAP01358
33	Grande bielle/planche niveleuse ROLLMOT/MAX	Kurbelarm/	Crank/	Brazo/		RAP01359
34	Rondelle plate 14x35x3 Zn/	Scheibe Ø14x35x3/	Washer Ø14x35x3/	Arandela Ø14x35x3/	Плоская шайба 14x35x3 Zn/	RON01404
35	Rondelle plate 20x45x2/	Scheibe 20x45x2/	Washer 20x45x2/	Arandela 20x45x2/		RON02002
36	Rondelle plate 21x40x4 Zn/	Scheibe/	Washer/	Arandela/		RON02003
37	Rondelle plate 25x45x3/Remplacé par RON02515	Scheibe Ø25x45x3/	Washer Ø25x45x3/	Arandela Ø25x45x3/	Плоская шайба 25x45x3/	RON02508
38	Soc pour dent niveleuse de/ROLLMOT 210355081	Schar/	Schare/	Reja/		SOC21020
39	Vérin DE: 30x 60 C: 200 EF:500/autopurge	Zylinder/	Cylinder/	Cilindro hidraulico/		VER03035
40	Vérin DE: 35x 70 C: 200 EF:500/autopurge	Zylinder/	Cylinder/	Cilindro hidraulico/		VER03536
41	Vérin DE: 40x80 C: 196 EF:502/auto purge	Zylinder/	Cylinder/	Cilindro hidraulico/		VER04034
42	Soc broyeur de croûtes/pour dent niveleuse ROLLMOT	Schar/	Share/	Reja/		SOC21035
43	Diviseur de débit entrée/1/2 G sortie 1/2 G (HYDAC)	Ausstoßteiler/	Flow divider/	divisor del flujo/	Делитель расхода/	HYD00021

Planche N°5 : ROLLMOT / ROLLMAX
Bras + sections latérales

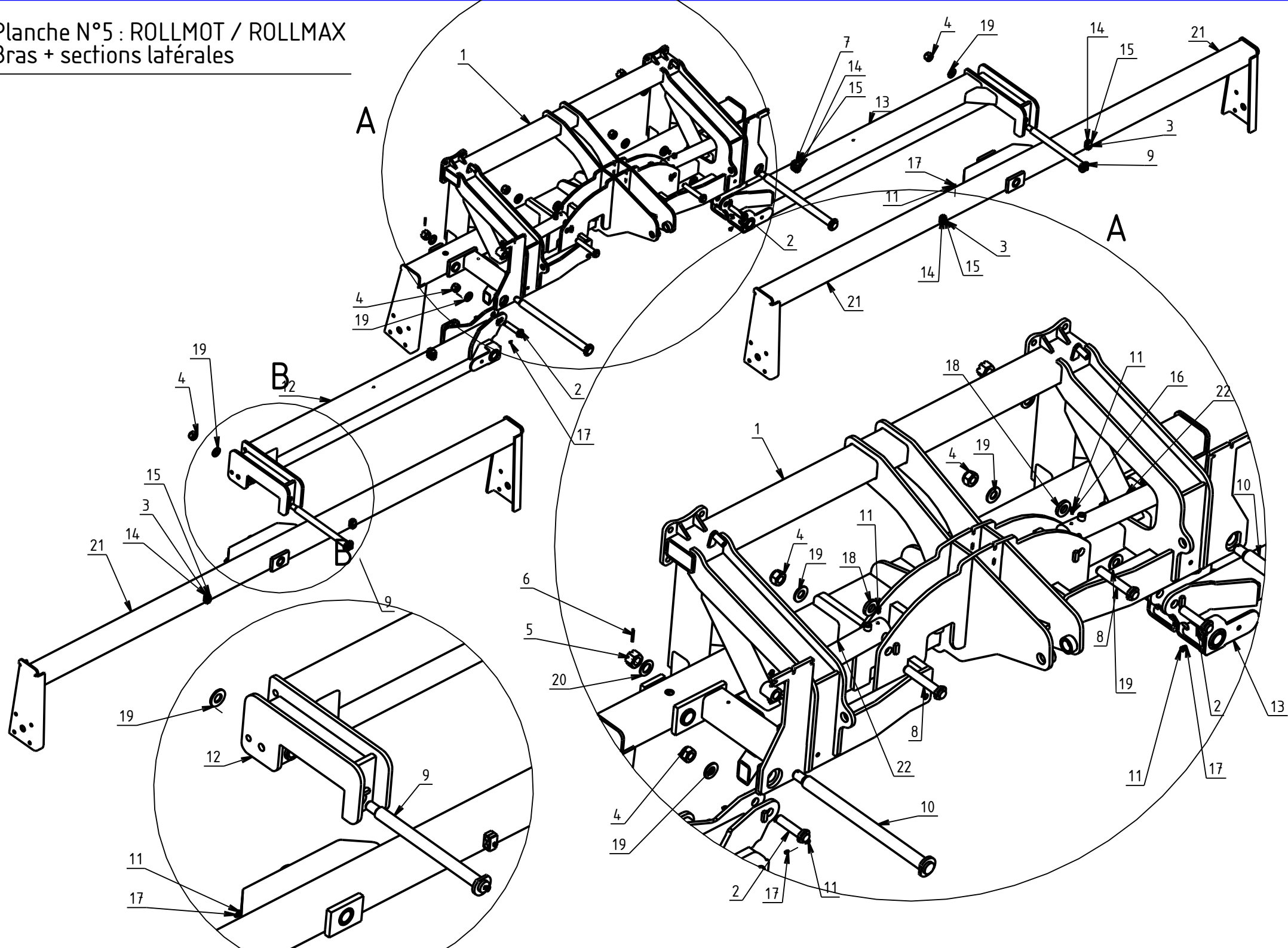

ROLLMOT/ROLLMAX 10m30 (catalogue)

Rep.	Nom du produit	Beschreibung	Description	Designacion	Наименование	Code
1	Partie arrière ROLLMAX 10M30/bi-poutres 200x100	Rahmen/	Main frame/	Cajonera/		RAP01233
2	Axe Ø 30x125 M30 (acier)/(sous tête)	Achse Ø30x125/	Axle Ø30x125/	Eje Ø30x125/		AXE30022
3	Vis T.H. 8x 35 8.8 Zn/filetage total	Schraube/	Screw/	Tornillo/	Винт Т.Н. 8x 35 8.8 Zn лол	VIS08025
4	Ecrou nylstop M30 Zn/	Mutter M30/	Nut M30/	Tuerca M30/	Гайка nylstop M30 Zn/	ECR30002
5	Ecrou creneaux HK M33x200/	Mutter M33x300/	Nut M33x300/	Tuerca M33x300/	Гайка M33x200/	ECR33006
6	Goupille mécanindus 6 x 50/épaisse DIN1481	Stift 6x50/	Pin 6x50/	Pasador 6x50/	Штифт 6x 50/	GOU06002
7	Vis T.H. 8x 60 8,8 Zn/	Schraube 8x60/	Screw 8x60/	Tornillo 8x60/	Болт Т.Н. 8x 60 8,8 Zn/	VIS08026
8	Axe Ø 30x170 (acier) (sous têt/e) tête rectangulaire	Achse/	Axle/	Eje/		AXE30014
9	Axe Ø 40x520 M30 (acier) (sous/tête) graissage en bou	Achse Ø40x520/	Axle Ø40x520/	Eje Ø40x520/		AXE40075
10	Axe Ø 45x670 M33x200 sous tête/	Achse/	Axle/	Eje/		AXE45055
11	Bouchon graissage ROUGE R3000/GPN 985/200	Stopfen/	Plug/	Tapòn/	Служская пробка /	BOU00037
12	Bras droit de ROLLMOT 1030/	Recht Kurbelarm/	Right crank/	Brazo derecha/		BRA00217
13	Bras gauche de ROLLMOT 1030/	Links Kurbelarm/	Left crank/	Brazo izquierda/		BRA00218
14	Fixation 2 flexibles Ø16/partie plastique	Flexible Befestigung Ø16/	Flexible mounting Ø16/	Montaje flexible Ø16/		DIV00008
15	Fixation flexible partie/capuchon tole	Flexible Teile Befestigung	Flexible part mounting cap c	Tapa de montaje de la pieza		DIV00106
16	Graisseur M 6 droit auto/taraudeur	Schmiernippel/	Grease nipple/	Engrasador/		GRA06001
17	Graisseur M 8 droit/	Schmiernippel/	Grease nipple/	Engrasador/	Масленка М 8 лрямая/	GRA08001
18	Rondelle plate 30,5x60x10/	Scheibe/	Washer/	Arandela/		RON03008
19	Rondelle plate 30x60x5/	Scheibe/	Washer/	Arandela/	Плоская шайба 30x60x5/	RON03003
20	Rondelle plate 35x60x4/	Scheibe 35x60x4/	Washer 35x60x4/	Arandela 35x60x4/	Плоская шайба 35x60x4/	RON03502
21	Section latérale Rollmax 10M30/tube lg 4200	Halter/	Bracket/	Soporte/		SEC00066
22	Vérin DE: 40x 70 C: 300 EF:510/A10033b réf 4073	Zylinder/	Cylinder/	Cilindro hidraulico/	Гидроцилиндр двойного дей	VER04011

Planche N°6.1 : ROLLMOT / ROLLMAX
Rouleaux lisses Ø610

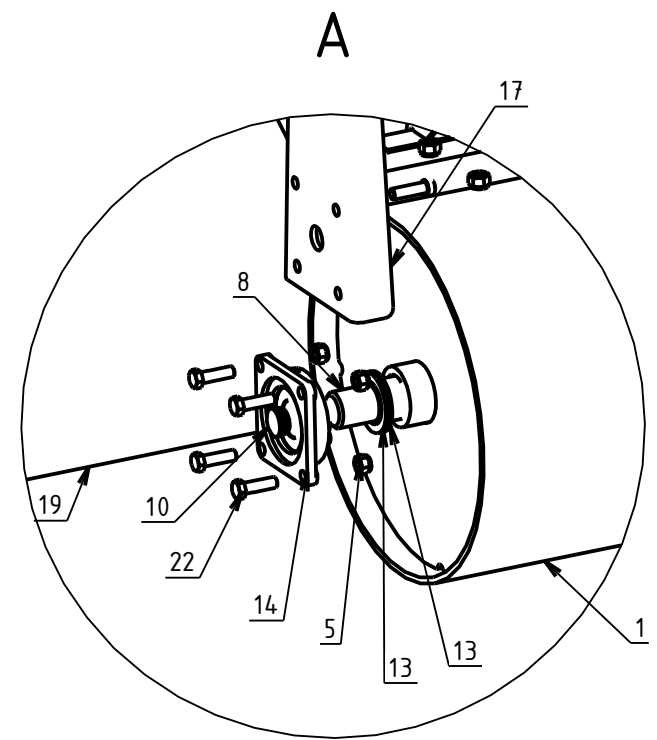
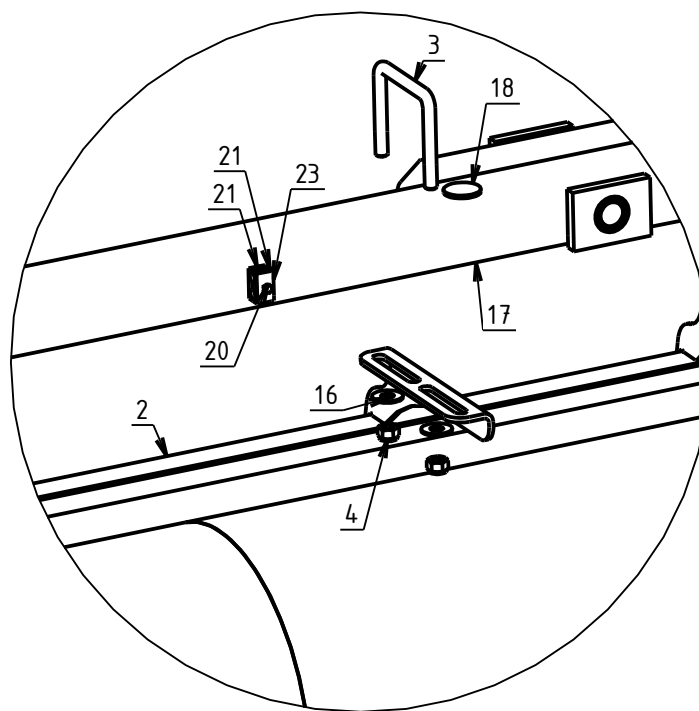
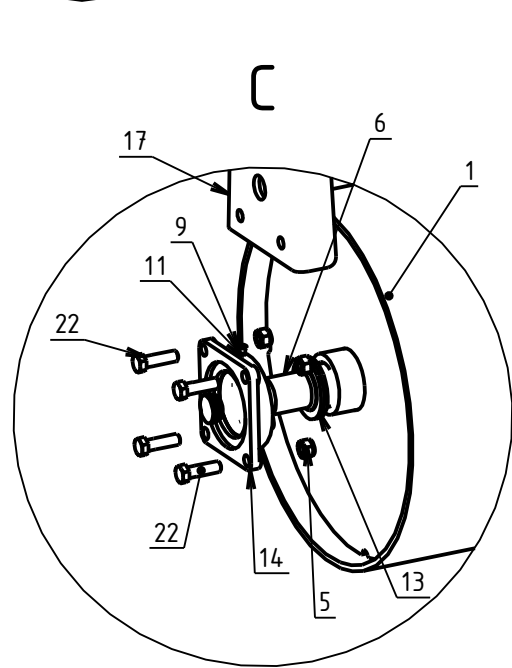
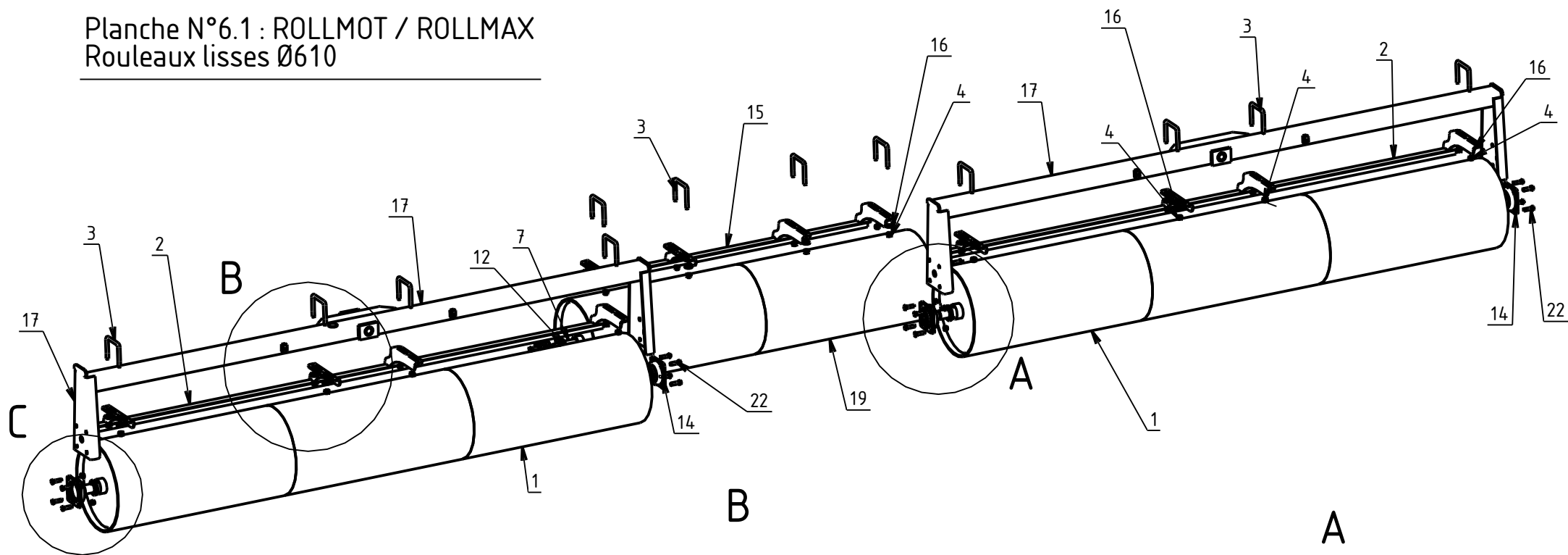

ROLLMOT/ROLLMAX 10m30 (catalogue)

Rep.	Nom du produit	Beschreibung	Description	Designacion	Наименование	Code
1	Module de rlx lisse Ø610x10 lg/1330 pour arbre Ø70	Walze/	Roller/	Rodillo/		RAP00046
2	Raclette sections DR & GA 9m50/nue ROLLMOT - RO					RAP01272
3	Etrier Ø20x152x145/40 XC38/	U- Bolzen Ø20x152x145/40/	U- Bolt Ø20x152x145/40/	Brida en U Ø20x152x145/40	Скоба Ш20x152x145/40 X	ETR20006
4	Ecrou nylstop M20 Zn/DIN 985	Mutter M20/	Nut M20/	Tuerca M20/	Гайка nylstop M20 Zn DIN 9	ECR20003
5	Ecrou nylstop M18 Zn/	Mutter M18/	Nut M18/	Tuerca M18/	Гайка nylstop M18 Zn/	ECR18002
6	Arbre Ø 70 lg 4220/	Welle/	Shaft/	Arbol/	Вал Ш 70 дл 4220/	ARB07035
7	Arbre Ø 70 lg 2790 (en DFO)/PC rollmot/rollmax 10m30 Scheiben Welle/		Disc shaft/	Arbol de disco/		ARB07092
8	Arbre Ø 70 lg 4180 (Etiré A60)/section rollmot/rollmax 1 Scheiben Welle/		Disc shaft/	Arbol de disco/		ARB07093
9	Bouchon graissage ROUGE R3000/GPN 985/200	Stopfen/	Plug/	Tapòn/	Служкая лрбка /	BOU00037
10	Bouchon plastique GL 48x3,0-/4,0 noir	Stopfen/	Plug/	Tapòn/	Заглушка для трубы Ш40 in	BOU10013
11	Graisser M 8 droit/	Schmiernippel/	Grease nipple/	Engrasador/	Масленка М 8 лрямая/	GRA08001
12	Rondelle plate 61x85x5/	Scheibe/	Washer/	Arandela/	Плоская шайба 61x85x5/	RON06100
13	Rondelle plate 71x100x6/	Scheibe/	Washer/	Arandela/	Плоская шайба 71x100x6/	RON07101
14	Palier UCF 212 complet/	Lager UCF 212/	Bearing UCF 212/	Cojinete UCF 212/	Подшипник в сборе UCF 21	PAL06000
14	Palier UCF 212 complet graissé/à vie (sans entretien)	Lager/	Bearing/	Cojinete/		PAL06002
15	Raclette centrale 4m30 à 9m50/nue ROLLMOT - ROLL					RAP01260
16	Rondelle plate 20L NFE25513/	Scheibe/	Washer/	Arandela/	Плоская шайба 20L NFE255	RON02004
17	Section latérale Rollmax 10M30/tube lg 4200	Halter/	Bracket/	Soporte/		SEC00066
18	Catadioptr orange Ø60 adhésif/	Rückstrahler/	Reflector/	Reflector/		SIG00103
19	Module de rlx lisse Ø610x10 lg/1270 pour arbre Ø70	Walze/	Roller/	Rodillo/		RAP00044
20	Vis T.H. 8x 35 8.8 Zn/filetage total	Schraube/	Screw/	Tornillo/	Винт Т.Н. 8x 35 8.8 Zn лол	VIS08025
21	Fixation 2 flexibles Ø16/partie plastique	Flexible Befestigung Ø16/	Flexible mounting Ø16/	Montaje flexible Ø16/		DIV00008
22	Fixation flexible partie/capuchon tole	Flexible Teile Befestigung	Flexible part mounting cap c	Tapa de montaje de la pieza		DIV00106
23	Vis T.H. 18x 60 8.8 Zn/Classe 8,8 DIN931	Schraube 18x60/	Screw 18x60/	Tornillo 18x60/	Болт Т.Н.18x 60 8.8 Zn/	VIS18003

Planche N°6.2 ROLLMOT - ROLLMAX:
Rouleaux lisses Ø710 - Ø730

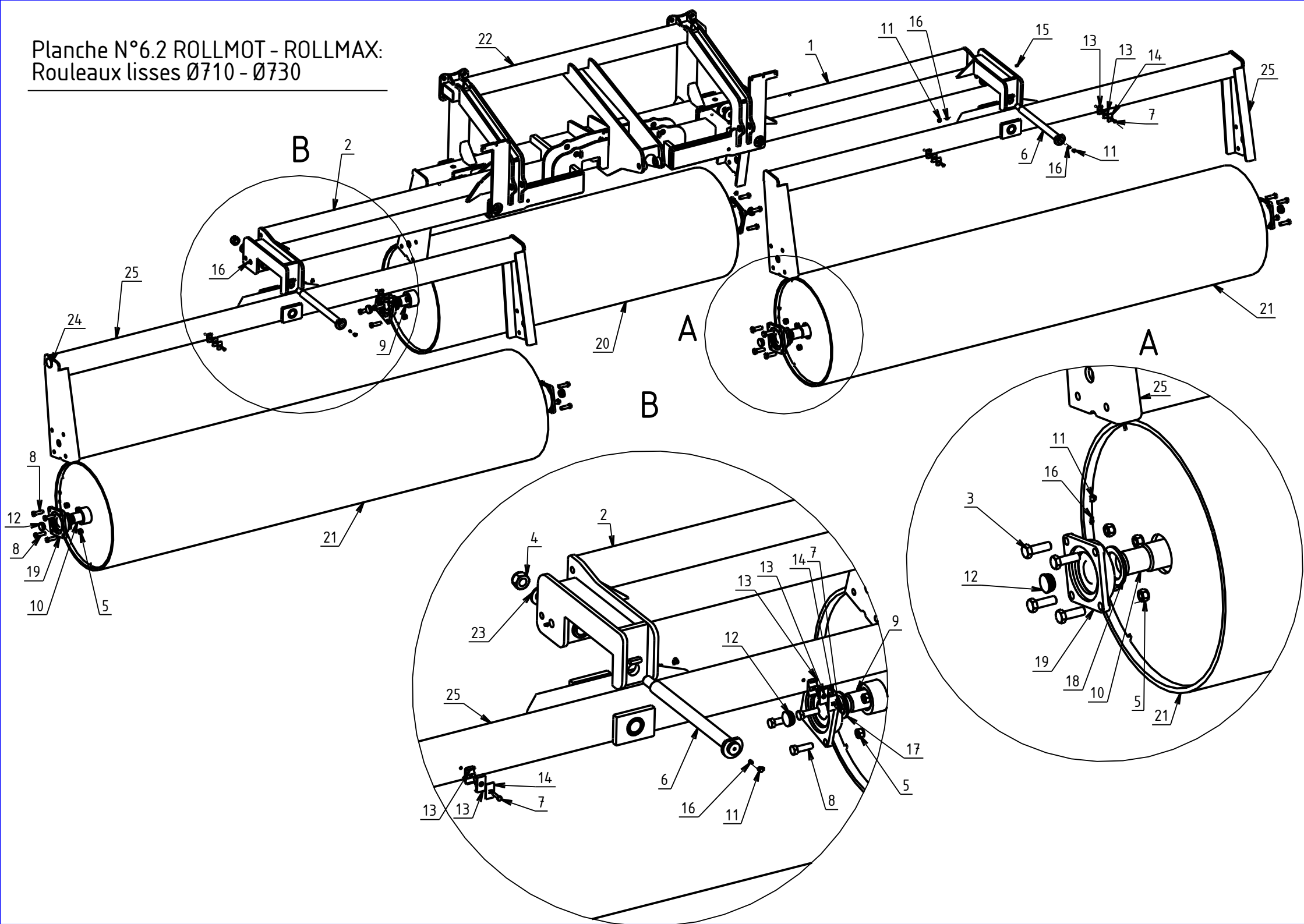

ROLLMOT/ROLLMAX 10m30 (catalogue)

Rep.	Nom du produit	Beschreibung	Description	Designacion	Наименование	Code
1	Bras gauche de ROLLMOT 1030/	Links Kurbelarm/	Left crank/	Brazo izquierda/		BRA00218
2	Bras droit de ROLLMOT 1030/	Recht Kurbelarm/	Right crank/	Brazo derecha/		BRA00217
3	Vis T.H. 20x 60 8,8 Zn/	Schraube 20x60/	Screw 20x60/	Tornillo 20x60/	Болт Т.Н.20x 60 8,8 Zn/	VIS20031
4	Ecrou nylstop M30 Zn/	Mutter M30/	Nut M30/	Tuerca M30/	Гайка nylstop M30 Zn/	ECR30002
5	Ecrou nylstop M18 Zn/	Mutter M18/	Nut M18/	Tuerca M18/	Гайка nylstop M18 Zn/	ECR18002
6	Axe Ø 40x520 M30 (acier) (sous/tête) graissage en bou	Achse Ø40x520/	Axle Ø40x520/	Eje Ø40x520/		AXE40075
7	Vis T.H. 8x 35 8.8 Zn/filetage total	Schraube/	Screw/	Tornillo/	Винт Т.Н. 8x 35 8.8 Zn лол	VIS08025
8	Vis T.H. 18x 60 8.8 Zn/Classe 8,8 DIN931	Schraube 18x60/	Screw 18x60/	Tornillo 18x60/	Болт Т.Н.18x 60 8.8 Zn/	VIS18003
9	Arbre Ø 70 lg 2380 (XC48)/	Welle/	Shaft/	Arbol/	Вал Ш 70 дл. 2380/	ARB07018
10	Arbre Ø 70 lg 3390/	Welle/	Shaft/	Arbol/	Вал Ш 70 дл 3390/	ARB07043
11	Bouchon graissage ROUGE R3000/GPN 985/200	Stopfen/	Plug/	Tapòn/	Служная пробка /	BOU00037
12	Bouchon plastique GL 48x3,0-/4,0 noir	Stopfen/	Plug/	Tapòn/	Заглушка для трубы Ш40 in	BOU10013
13	Fixation 2 flexibles Ø16/partie plastique	Flexible Befestigung Ø16/	Flexible mounting Ø16/	Montaje flexible Ø16/		DIV00008
14	Fixation flexible partie/capuchon toile	Flexible Teile Befestigung	Flexible part mounting cap c	Tapa de montaje de la pieza		DIV00106
15	Graisseur M 6 droit auto/taraudeur	Schmiernippel/	Grease nipple/	Engrasador/		GRA06001
16	Graisseur M 8 droit/	Schmiernippel/	Grease nipple/	Engrasador/	Масленка М 8 лрямая/	GRA08001
17	Rondelle plate 61x85x5/	Scheibe/	Washer/	Arandela/	Плоская шайба 61x85x5/	RON06100
18	Rondelle plate 71x100x6/	Scheibe/	Washer/	Arandela/	Плоская шайба 71x100x6/	RON07101
19	Palier UCF 212 complet/	Lager UCF 212/	Bearing UCF 212/	Cojinete UCF 212/	Подшипник в сборе UCF 21	PAL06000
19	Palier UCF 212 complet graissé/à vie (sans entretien)	Lager/	Bearing/	Cojinete/		PAL06002
20	Rouleau tube acier Ø711x12,5/lg 2250, arbre Ø70	Walze/	Roller/	Rodillo/		RAP00056
21	Rouleau tube acier Ø711x12,5/lg 3260, arbre Ø70	Walze/	Roller/	Rodillo/		RAP00062
22	Partie arrière ROLLMAX/Ø710 & Ø730 - 8m30 à 9m50					RAP01241
23	Rondelle plate 30x60x5/	Scheibe/	Washer/	Arandela/	Плоская шайба 30x60x5/	RON03003
24	Catadioptr blanc Ø54 adhésif/	Rückstrahler/	Reflector/	Reflector/		SIG00100
25	Section latérale Ø710 & Ø730/Rollmax 10m30, tube lg					SEC00076

Planche N°6.3 : ROLLMOT / ROLLMAX
Rouleau roues fonte

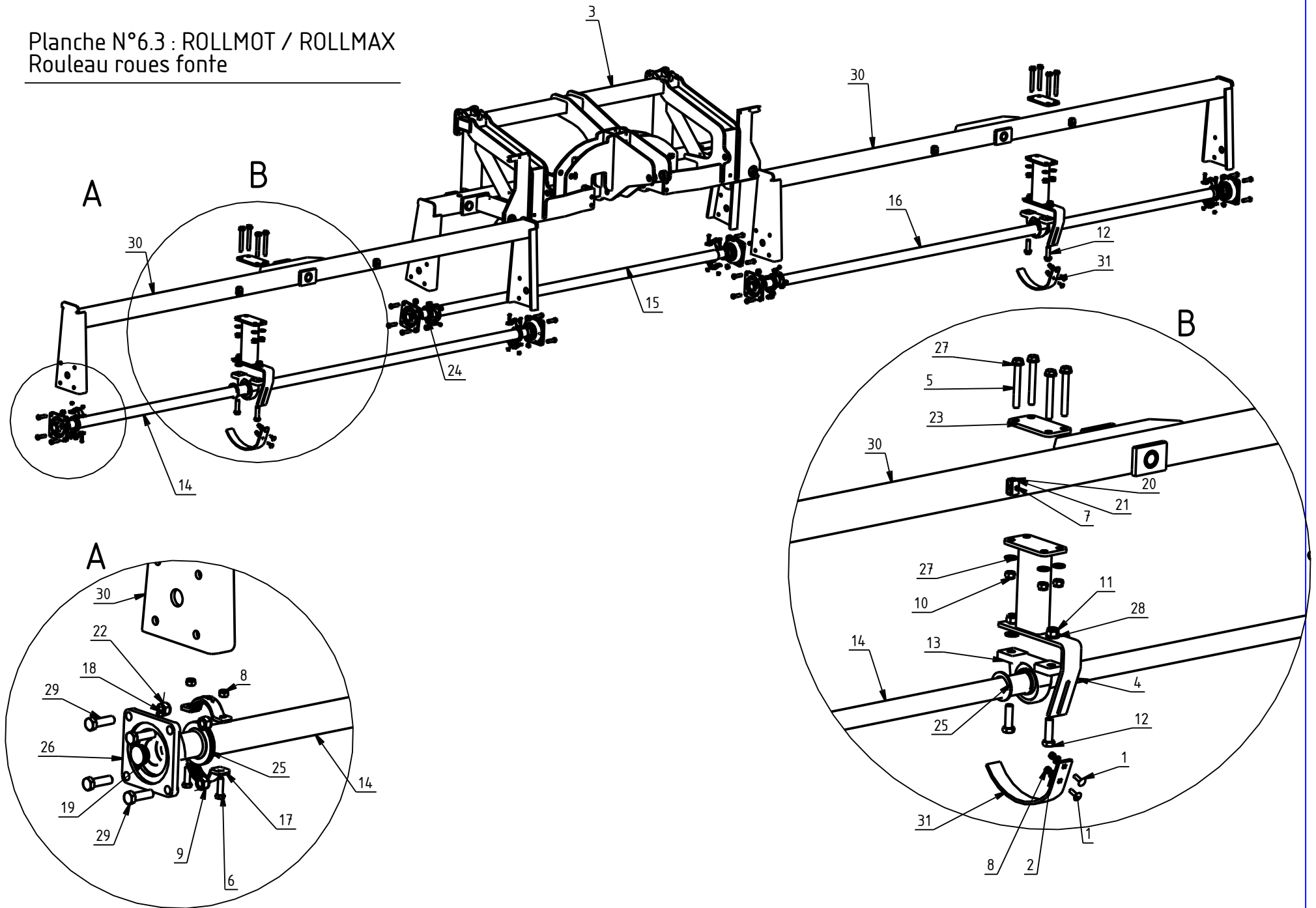

ROLLMOT/ROLLMAX 10m30 (catalogue)

Rep.	Nom du produit	Beschreibung	Description	Designacion	Наименование	Code
1	Vis T.R.C.C. 12x40 8.8/DIN603-8,8	Schraube/	Screw/	Tornillo/		VIS12086
2	Rondelle plate 12 Zn/	Scheibe/	Washer/	Arandela/	Плоская шайба/	RON01204
3	Partie arrière ROLLMAX 10M30/bi-poutres 200x100	Rahmen/	Main frame/	Cajonera/		RAP01233
4	Support palier interméd HT 320/arbre Ø70 (chassis 150	Halter/	Bracket/	Soporte/		RSR02033
5	Vis T.H. 20x160 8.8 Zn/	Schraube 20x160/	Screw 20x160/	Tornillo 20x160/	Винт Т.Н.20x160 8.8 Zn/	VIS20042
6	Vis T.H. 12x 40 8.8 Zn/	Schraube 12x40/	Screw 12x40/	Tornillo 12x40/	Болт Т.Н.12x 40 8.8 Zn/	VIS12037
7	Vis T.H. 8x 35 8.8 Zn/filetage total	Schraube/	Screw/	Tornillo/	Винт Т.Н. 8x 35 8.8 Zn лол	VIS08025
8	Ecrou nylstop M12 Zn/DIN 985	Mutter M12/	Nut M12/	Tuerca M12/	Гайка nylstop M12 Zn DIN 9	ECR12002
9	Ecrou nylstop M18 Zn/	Mutter M18/	Nut M18/	Tuerca M18/	Гайка nylstop M18 Zn/	ECR18002
10	Ecrou nylstop M20 Zn/DIN 985	Mutter M20/	Nut M20/	Tuerca M20/	Гайка nylstop M20 Zn DIN 9	ECR20003
11	Ecrou nylstop M24 Zn/	Mutter M24/	Nut M24/	Tuerca M24/	Гайка nylstop M24 Zn/	ECR24003
12	Vis T.H. 24x 80 8,8 Zn/Remplacé par VIS24016	Schraube 24x80/	Screw 24x80/	Tornillo 24x80/	Болт Т.Н.24x 80 8,8 Zn/	VIS24005
13	Palier UCP 214/	Lager UCP 214/	Bearing UCP 214/	Cojinete UCP 214/	Корлус лодшилников UCP	PAL07002
14	Arbre Ø 70 lg 4220/	Welle/	Shaft/	Arbol/	Вал Ш 70 дл 4220/	ARB07035
15	Arbre Ø 70 lg 2790 (en DFO)/PC rollmot/rollmax 10m30	Scheiben Welle/	Disc shaft/	Arbol de disco/		ARB07092
16	Arbre Ø 70 lg 4180 (Etiré A60)/section rollmot/rollmax 1	Scheiben Welle/	Disc shaft/	Arbol de disco/		ARB07093
17	Bride 1/2 de rattrapage de jeu/pour arbre Ø70 (N°0844/	Bride½/	Bridle½/	Brida½/	Фланеч 1/2 /	BAG07005
18	Bouchon graissage ROUGE R3000/GPN 985/200	Stopfen/	Plug/	Tapòn/	Слускная лробка /	BOU00037
19	Bouchon plastique GL 48x3,0-/4,0 noir	Stopfen/	Plug/	Tapòn/	Заглушка для трубы Ш40 in	BOU10013
20	Fixation 2 flexibles Ø16/partie plastique	Flexible Befestigung Ø16/	Flexible mounting Ø16/	Montaje flexible Ø16/		DIV00008
21	Fixation flexible partie/capuchon tole	Flexible Teile Befestigung	Flexible part mounting cap c	Tapa de montaje de la pieza		DIV00106
22	Graisseur M 8 droit/	Schmiernippel/	Grease nipple/	Engrasador/	Масленка М 8 лрямая/	GRA08001
23	Contre plaque de support/rouleau ROLLMOT/MAX	Platte/	Plate/	Placa/		RAP01247
24	Rondelle plate 61x85x5/	Scheibe/	Washer/	Arandela/	Плоская шайба 61x85x5/	RON06100
25	Rondelle plate 71x100x6/	Scheibe/	Washer/	Arandela/	Плоская шайба 71x100x6/	RON07101
26	Palier UCF 212 complet/	Lager UCF 212/	Bearing UCF 212/	Cojinete UCF 212/	Подшилник в сборе UCF 21	PAL06000
26	Palier UCF 212 complet graissé/à vie (sans entretien)	Lager/	Bearing/	Cojinete/		PAL06002

ROLLMOT/ROLLMAX 10m30 (catalogue)

Rep.	Nom du produit	Beschreibung	Description	Designacion	Наименование	Code
27	Rondelle plate 21x40x4 Zn/	Scheibe/	Washer/	Arandela/		RON02003
28	Rondelle plate 25x45x4 ZI/Zinguée	Scheibe/	Washer/	Arandela/		RON02515
29	Vis T.H. 18x 60 8.8 Zn/Classe 8,8 DIN931	Schraube 18x60/	Screw 18x60/	Tornillo 18x60/	БОЛТ Т.Н.18x 60 8.8 Zn/	VIS18003
30	Section latérale Rollmax 10M30/tube lg 4200	Halter/	Bracket/	Soporte/		SEC00066
31	Soc de languette ré-appuyage/LAMFLEX	Schar/	Share/	Reja/		SOC10062

Planche N°6.4 : ROLLMOT / ROLLMAX
Roues fonte

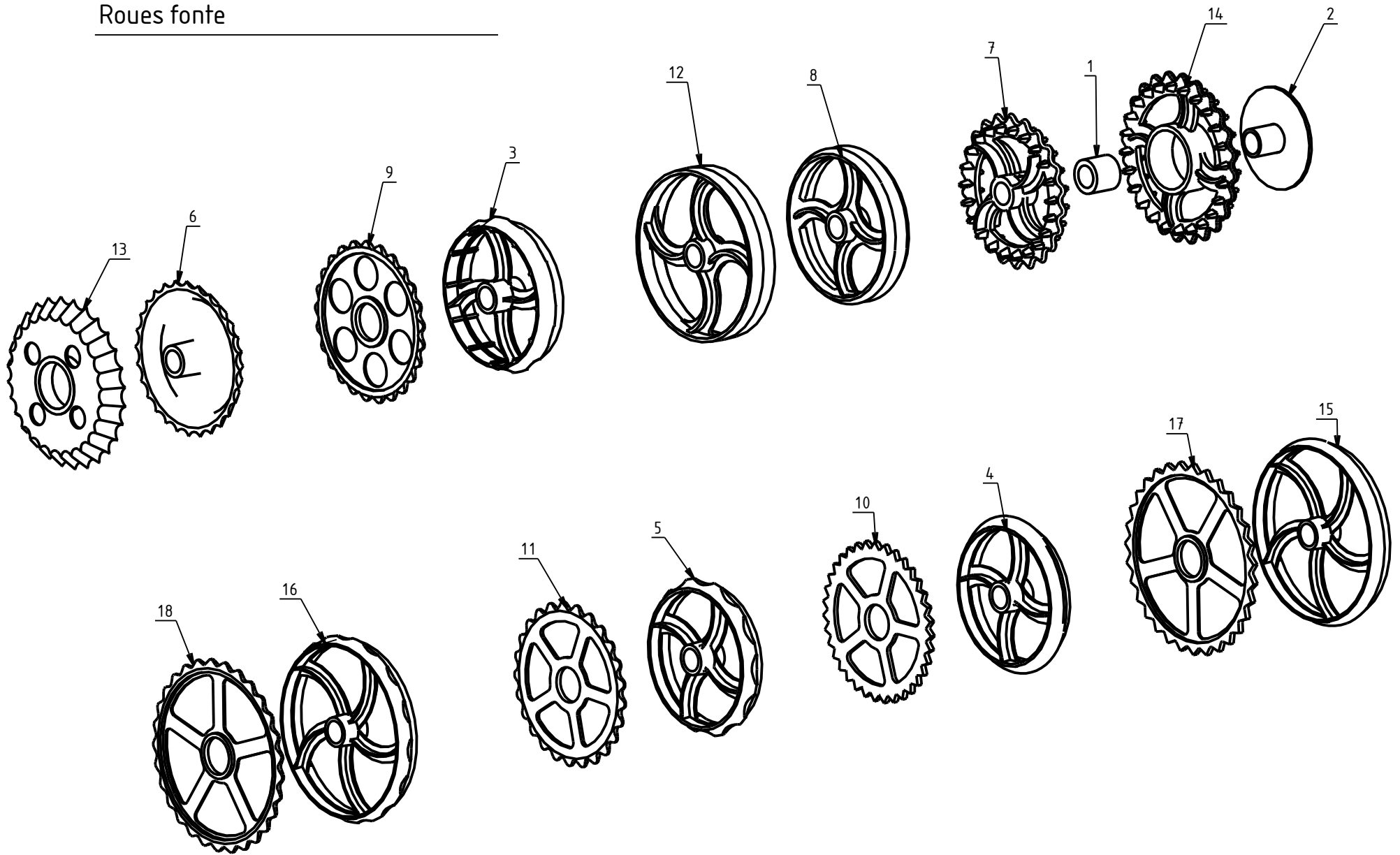

ROLLMOT/ROLLMAX 10m30 (catalogue)

Rep.	Nom du produit	Beschreibung	Description	Designacion	Наименование	Code
1	Moyeu de roue croskill lourd Ø/70 N°5022/92	Nabe/	Hub/	Cubo/	Стулица колеса тяжелого ка	MOY00008
2	Rondelle d'arrêt pour roue/croskill Ø550	Scheibe/	Washer/	Arandela/	Столорная шайба для коле	RAP00025
3	Roue cambridge ondulée Ø500/72/largeur 125 rollfirst	Ringelwalze/	Ring roller/	Rodillo de discos/		RFT50702
4	Roue cambridge Ø505/70/(4 branches)	Ringelwalze/	Ring roller/	Rodillo de discos/	Колесо Ш505/70/	RFT50703
5	Roue cambridge ondulée Ø505/70/(4 branches)	Ringelwalze/	Ring roller Ø505/70/	Rodillo de discos/	Колесо гофрированное Ш50	RFT50704
6	Roue GUT Ø500/72/lar 120 fonte ductile GJS-500-7		Ductile prismatic cast iron/Ø			RFT50709
7	Roue croskill lourd Ø500/70/N°5021/92	Ringelwalze/	Ring roller/	Rodillo de discos/	Колесо тяжелого катка Ш50	RFT50751
8	Roue ondulée Ø500/70 largeur/100 mm	Ringelwalze/	Ring roller/	Rodillo de discos/	Колесо гофрированное Ш50	RFT50752
9	Roue Cambridge ondulée crénelé/Ø520/70 Rollfirst	Ringelwalze/	Ring roller/	Rodillo de discos/		RFT52701
10	Roue cambridge crenelé Ø530/70/	Ringelwalze/	Ring roller/	Rodillo de discos/	Колесо зубчатое Ш530/70/	RFT53750
11	Roue cambridge ondulée crenelé/e Ø530/70	Ringelwalze/	Ring roller Ø530/70/	Rodillo de discos/	Колесо гофрировано-зубчат	RFT53751
12	Roue lisse Ø556/70 largeur/100 mm	Ringelwalze/	Ring roller/	Rodillo de discos/	Гладкое колесо Ш556/70 ши	RFT55701
13	Roue GUT Ø550/72/lar 56,5 fonte ductile GJS-500-7	Ringelwalze/	Ring roller/	Rodillo de discos/		RFT55709
14	Roue croskill lourd Ø550/190/N°5092/92	Ringelwalze/	Ring roller/	Rodillo de discos/	Колесо тяжелого катка Ш55	RFT55750
15	Roue cambridge Ø600/72-5branch/fonte ductile GJS-5	Ringelwalze/	Ring roller/	Rodillo de discos/		RFT60752
16	Roue camb ond Ø600/72-5 bras/fonte ductile GJS-500-	Ringelwalze/	Ring roller/	Rodillo de discos/	Колесо гофрированное Ш50	RFT60753
17	Roue cambridge creneléØ620/118/fonte ductile GJS-50	Ringelwalze/	Ring roller/	Rodillo de discos/		RFT62751
18	Roue cam ond cr GJS Ø620/72/fonte ductile GJS-500-	Ringelwalze/	Ring roller/	Rodillo de discos/	Колесо гофрированное Ш50	RFT62752

Planche N°7.1 : ROLLMOT / ROLLMAX
Kit hydraulique - Vérins de relevage

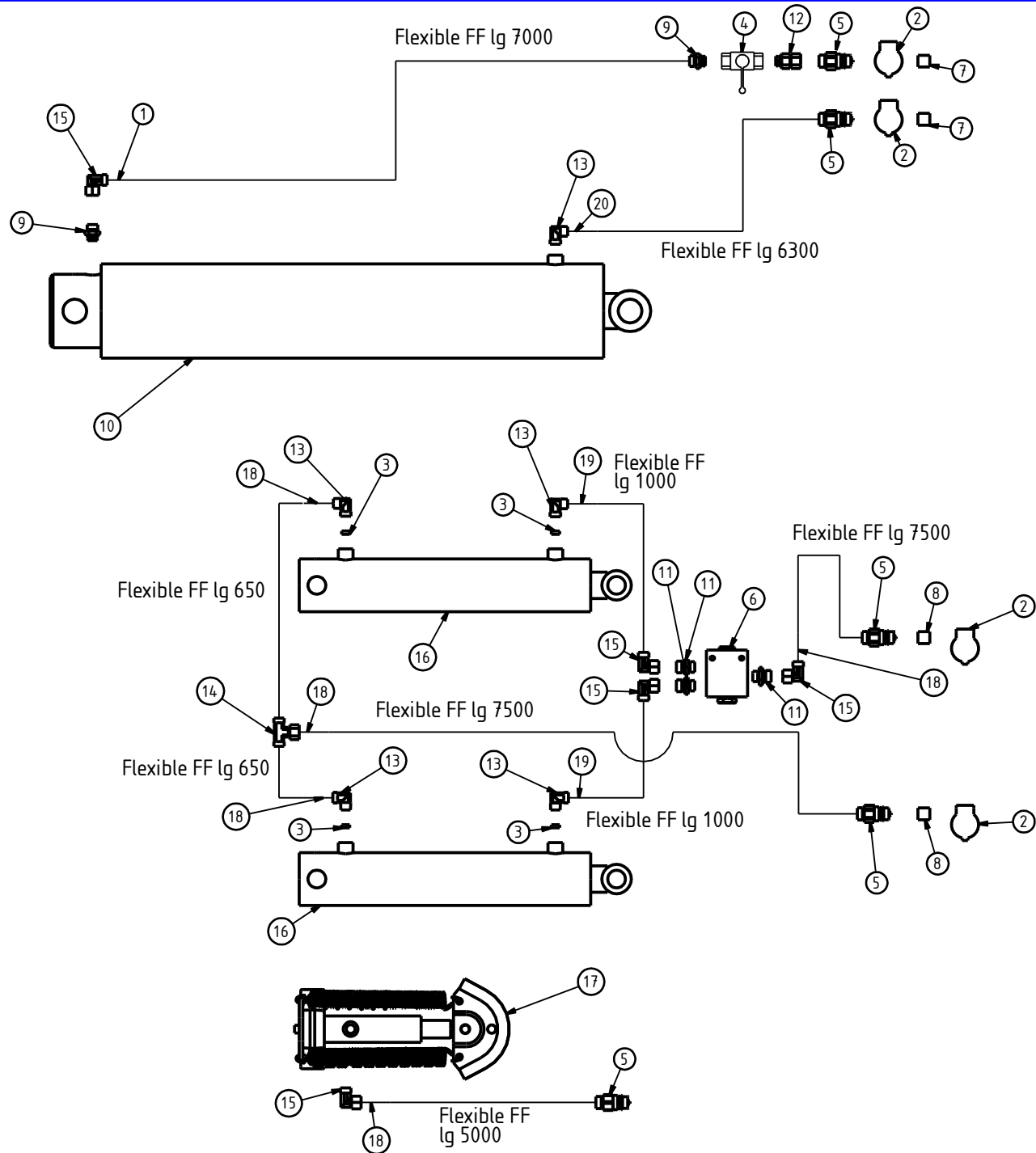

ROLLMOT/ROLLMAX 10m30 (catalogue)

Rep.	Nom du produit	Beschreibung	Description	Designacion	Наименование	Code
1	Flexible FF 12L Ig 7000/TD2C8 EFR12L-EFR12L	Schlauch/	Hydraulic hose/	Tuberia/	Шланг FF TD2C8 EFR12L-	FFD07008
2	Support coupleur femelle/	Halter/	Bracket/	Soporte/		HYD10720
2	Capuchon de coupleur/noir rigide pour HYD10720	Stopfen/	Plug/	Tapòn/	Коллачок муфты/	HYD00308
3	Pastille limiteur de débit/(h=5,55) DRE14	Mengenregler/	Spread control/	Limitador de volumen/	Пластина, ограничивающая	HYD02100
4	Robinet 2 voies F 3/8/	Hahn/	Tap/	Espita/	Кран с 2 выходами 8 FG 3/8	HYD00023
5	Coupleur male G1/2 à clapet/(male 18x150 (12L))	Kuppler/	Coupler/	Cuerpo/	Муфта наружная 1/2 шарик	HYD10710
6	Diviseur de débit entrée/1/2 G sortie 1/2 G (HYDAC)	Ausstoßteiler/	Flow divider/	divisor del flujo/	Делитель расхода/	HYD00021
7	Marqueur de flexible "bleu"/(bague plastique)	Schlauchmarker "blau"/	Hose marker "blue"/	Marcador de manguera "		HYD00309
8	Marqueur de flexible "jaune"/(bague plastique)	Schlauchmarker "gelb"/	Hose marker "yellow"/	Marcador flexible "amarill		HYD00310
9	Union M 12L - M G3/8 cyl/	Ölanschluss/	Oil connector/	Empalme/	Соединение М 12L - М 3/	HYD10076
10	Vérin DE: 60x140 C: 695 EF:945/trous Ø40,25 (des 2 c	Zylinder/	Cylinder/	Cilindro hidraulico/	Гидроцилиндр/	VER06014
11	Union M 12L - M G1/2 cyl/	Ölanschluss/	Oil connector/	Empalme/	Соединение М 12L - М 1/2 /	HYD10077
12	Union F 12L - M G3/8 cyl/tournant	Ölanschluss/	Oil connector/	Empalme/	Переходник (с вращающейс	HYD10201
13	Coude M 12L - M G3/8 conique/	Ölanschluss/	Oil connector/	Empalme/	Колено наружное коническо	HYD10305
14	Té égal M 12L/	Ölanschluss/	Oil connector/	Empalme/	Тройник равный 10A12/	HYD10402
15	Coude tournant M 12L - F 12L/	Ölanschluss/	Oil connector/	Empalme/	Колено М 12L - F 12L/	HYD10452
16	Vérin DE: 45x 80 C: 300 EF:510/réf A14857 orifice Ø2	Zylinder/	Cylinder/	Cilindro hidraulico/		VER04528
17	Vérin SE: 30 (freinage)/(a ressort)	Zylinder/	Cylinder/	Cilindro hidraulico/	Гидроцилиндр простого дей	VER03010
19	Flexible FF 12L Ig 1000/TD2C8 EFR12L-EFR12L	Schlauch/	Hydraulic hose/	Tuberia/	Шланг FF TD2C8 EFR12L-E	FFD01008
20	Flexible FF 12L Ig 6300/TD2C8 EFR12L-EFR12L	Schlauch/	Hydraulic hose/	Tuberia/	Шланг FF TD2C8 EFR12L-E	FFD06308
21	Flexible FF 12L Ig 650/TD2C8 EFR12L-EFR12L	Schlauch/	Hydraulic hose/	Tuberia/	Шланг FF TD2C8 EFR12L-	FFD00658
22	Flexible FF 12L Ig 5000/TD2C8 EFR12L-EFR12L	Schlauch/	Hydraulic hose/	Tuberia/	Шланг FF TD2C8 EFR12L-E	FFD05008
23	Flexible FF 12L Ig 7500/TD2C8 EFR12L-EFR12L	Schlauch/	Hydraulic hose/	Tuberia/	Шланг FF TD2C8 EFR12L-E	FFD07508

Planche N°7.2 : ROLLMOT / ROLLMAX
Kit hydraulique - PLANCHE NIVELEUSE



Sens d'avancement machine

Planche latérale gauche

Planche latérale droite

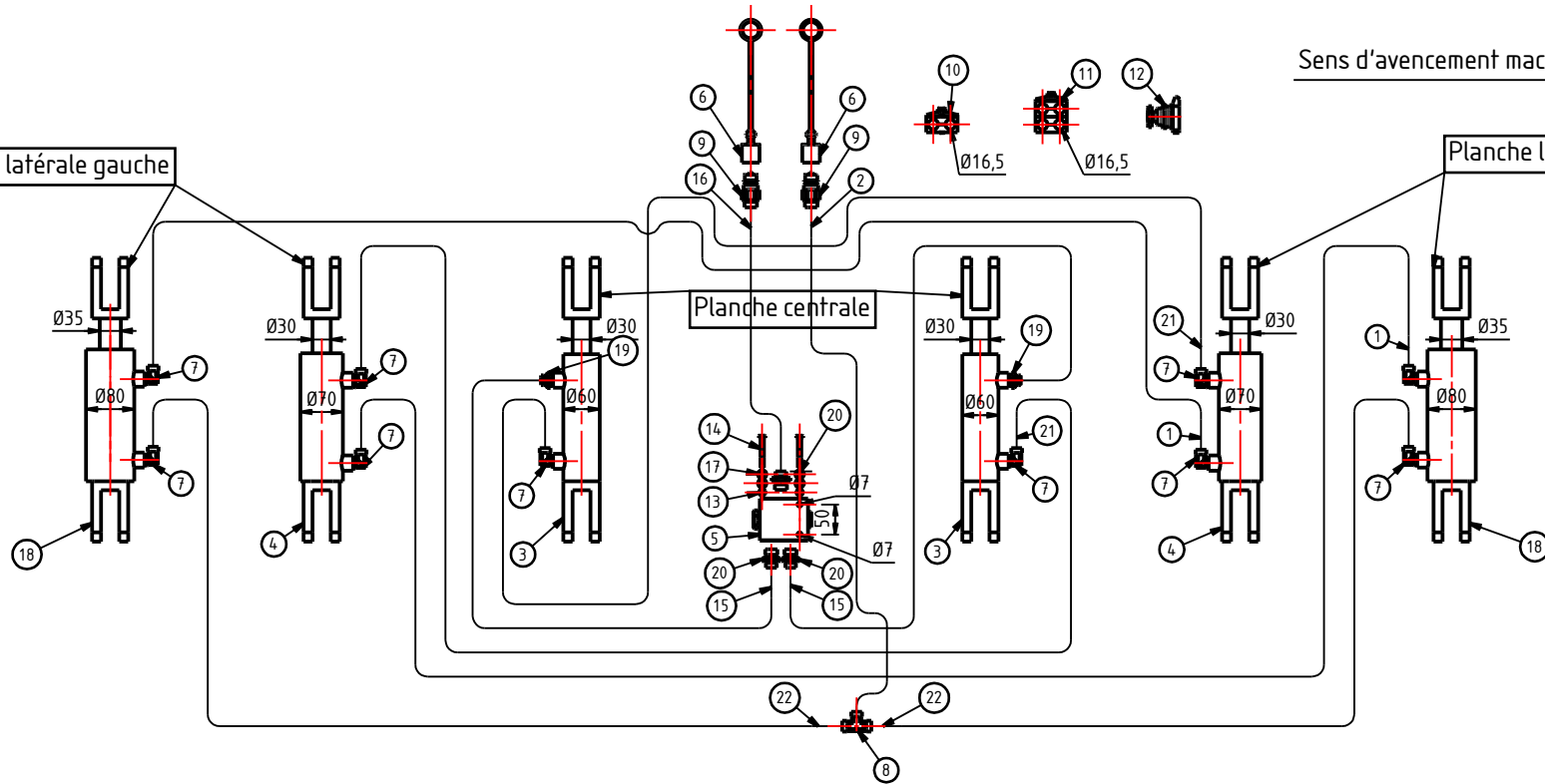

Pour montage bras ci-dessous

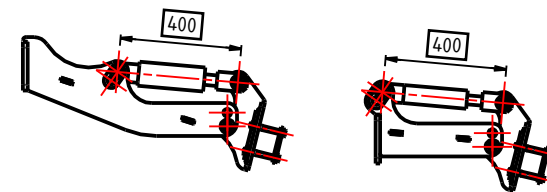

ROLLMOT/ROLLMAX 10m30 (catalogue)

Rep.	Nom du produit	Beschreibung	Description	Designacion	Наименование	Code
1	Flexible FF 12L Ig 8500/TD2C8 EFR12L-EFR12L	Schlauch/	Hydraulic hose/	Tuberia/	Шланг FF TD2C8 EFR12L-E	FFD08508
2	Flexible FF 12L Ig 7500/TD2C8 EFR12L-EFR12L	Schlauch/	Hydraulic hose/	Tuberia/	Шланг FF TD2C8 EFR12L-E	FFD07508
3	Vérin DE: 30x 50 C: 100 EF:400/autopurge	Zylinder/	Cylinder/	Cilindro hidraulico/		VER03027
4	Vérin DE: 30x 60 C: 100 EF:400/autopurge	Zylinder/	Cylinder/	Cilindro hidraulico/		VER03028
5	Diviseur de débit entrée/1/2 G sortie 1/2 G (HYDAC)	Ausstoßteiler/	Flow divider/	divisor del flujo/	Делитель расхода/	HYD00021
6	Capuchon de coupleur mâle/1/2 TF12 bleu REMPLAC	Stopfen/	Plug/	Tapòn/	Коллачок муфты 1/2 TF12 с	HYD00300
7	Coude M 12L - M G3/8 conique/	Ölanschluss/	Oil connector/	Empalme/	Колено наружное коническо	HYD10305
8	Té égal M 12L/	Ölanschluss/	Oil connector/	Empalme/	Тройник равный 10A12/	HYD10402
9	Coupleur male G1/2 à clapet/(male 18x150 (12L))	Kuppler/	Coupler/	Cuerpo/	Муфта наружная 1/2 шарик	HYD10710
10	Fixation 2 tuyau flexible Ø16/simple complète	Flansch/	Fastener/	Abrazadera/	Крепление гибкого шланга	DIV00006
11	Fixation 4 tuyau flexible Ø16/double complète	Flansch/	Fastener/	Abrazadera/	Крепление гибкого шланга	DIV00116
12	Support coupleur femelle/	Halter/	Bracket/	Soporte/		HYD10720
12	Capuchon de coupleur/noir rigide pour HYD10720	Stopfen/	Plug/	Tapòn/	Коллачок муфты/	HYD00308
13	Ecrou nylstop M 6 Zn/	Mutter M6/	Nut M6/	Tuerca M6/	Гайка M 6 Zn/	ECR06000
14	Vis T.H. 6x 50 8,8 Zn/Remplacé par VIS06032	Schraube/	Screw/	Tornillo/		VIS06016
15	Flexible FF 12L Ig 1000/TD2C8 EFR12L-EFR12L	Schlauch/	Hydraulic hose/	Tuberia/	Шланг FF TD2C8 EFR12L-E	FFD01008
16	Flexible FF 12L Ig 6500/TD2C8 EFR12L-EFR12L	Schlauch/	Hydraulic hose/	Tuberia/	Шланг FF TD2C8 EFR12L-E	FFD06508
17	Rondelle plate 6 Zn/NFE25513	Scheibe/	Washer/	Arandela/	Плоская шайба 6 Zn NFE25	RON00699
18	Vérin DE: 35x 70 C: 100 EF:400/autopurge	Zylinder/	Cylinder/	Cilindro hidraulico/		VER03533
19	Union M 12L - M G3/8 cyl/	Ölanschluss/	Oil connector/	Empalme/	Соединение M 12L - M 3/	HYD10076
20	Union M 12L - M G1/2 cyl/	Ölanschluss/	Oil connector/	Empalme/	Соединение M 12L - M 1/2 /	HYD10077
21	Flexible FF 12L Ig 5000/TD2C8 EFR12L-EFR12L	Schlauch/	Hydraulic hose/	Tuberia/	Шланг FF TD2C8 EFR12L-E	FFD05008
22	Flexible FF 12L Ig 5300/TD2C8 EFR12L-EFR12L	Schlauch/	Hydraulic hose/	Tuberia/	Шланг FF TD2C8 EFR12L-E	FFD05308

Planche N°8.1 : ROLLMOT / ROLLMAX
Freinage

FREINAGE reglement 2015-2008

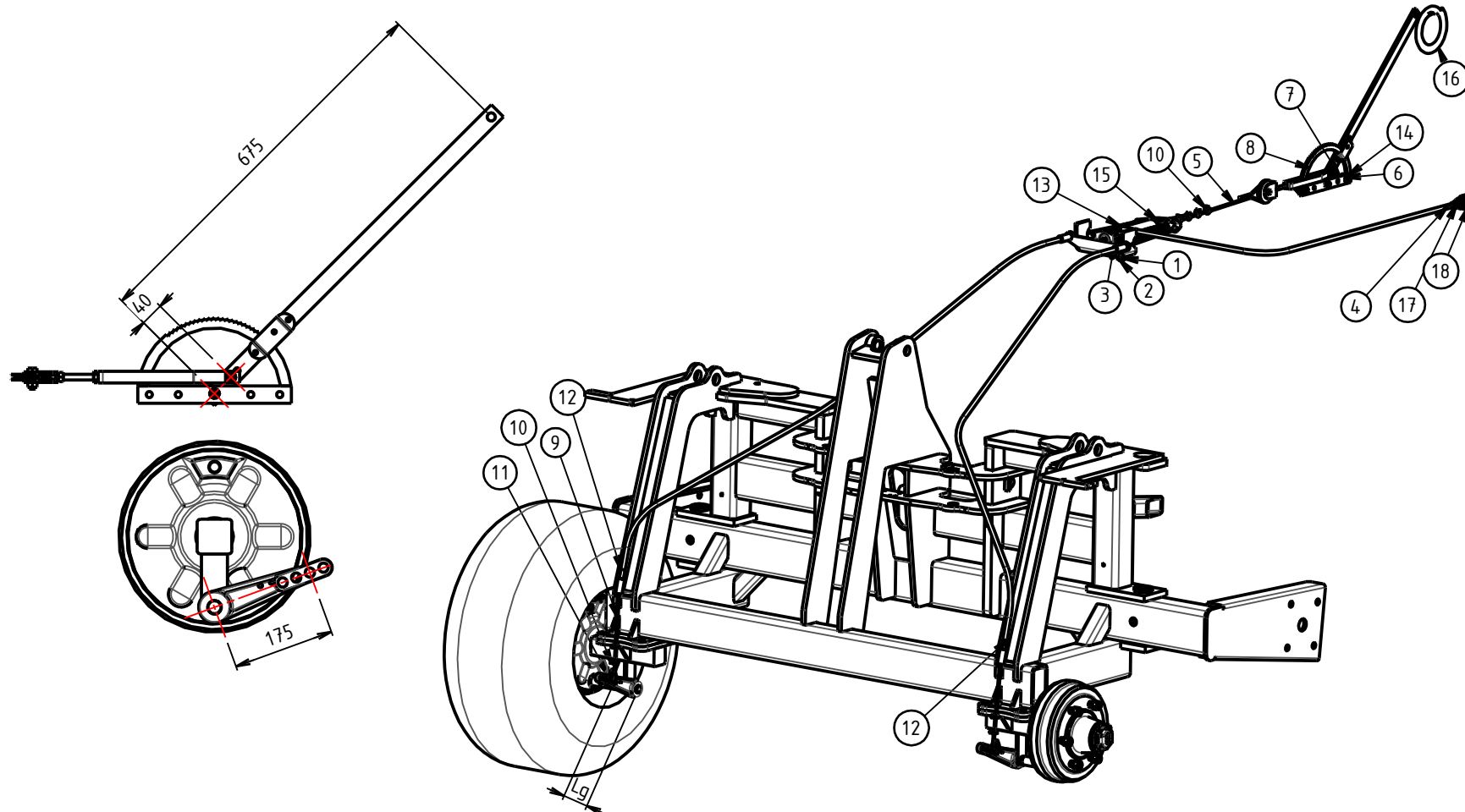

Marque essieu	Monroc
Lg	175 mm
Position du levier de frein à main	40 mm

ROLLMOT/ROLLMAX 10m30 (catalogue)

Rep.	Nom du produit	Beschreibung	Description	Designacion	Наименование	Code
1	Ecrou nylstop M14 Zn/	Mutter M14/	Nut M14/	Tuerca M14/	Гайка nylstop M14 Zn/	ECR14002
2	Vis T.H. 14x 45 8,8 Zn/filetage total	Schraube 14x45/	Screw 14x45/	Tornillo 14x45/	Болт Т.Н.14x45 8,8/	VIS14043
3	Rondelle plate 14x35x3 Zn/	Scheibe Ø14x35x3/	Washer Ø14x35x3/	Arandela Ø14x35x3/	Плоская шайба 14x35x3 Zn/	RON01404
4	Flexible FF 12L Ig 5500/TD2C8 EFR12L-EFR12L	Schlauch/	Hydraulic hose/	Tuberia/	Шланг FF TD2C8 EFR12L-E	FFD05508
5	Cable Ø 5,4 6x7 AMETEXTILLE/(au mètre)	Kabel/	Cable/	Cable/	Трос Ш 5,4 6x7 /	CAB00101
6	Vis T.H. 10x 40 8.8 Zn/filetage total	Schraube/	Screw/	Tornillo/		VIS10011
7	Ecrou nylstop M10 Zn/DIN 985 0871	Mutter M10/	Nut M10/	Tuerca M10/	Гайка nylstop M10 Zn/	ECR10002
8	Frein à main n°3 GRCHAPE/40/55 16.88 (nu)	Handbremse/	Handbrake/	Freno de mano/		FRE00104
8	Poulie Ø 60 pour cable frein +/ch+tige fil	Scheibe/	Pulley/	Polea/	Шкив Ш 60 для троса /	FRE00103
9	Cable Ø 5,4 6x7 AMETEXTILLE/(au mètre)	Kabel/	Cable/	Cable/	Трос Ш 5,4 6x7 /	CAB00101
10	Serre-câble Ø 5/	Klammer/	Clamp/	Abrazadera de presion/	Зажим троса Ш 6/	DIV00013
11	Cosse coeur Ø 5/	Kabelstellring/	cable collar/	collar del cable/		DIV00014
12	Gaine Øext 14mm pour câble/Ø6,3 (au mètre)	Gehäuse/	Leg/	Conducto/	Трубка, наружн. Ш 14 мм д	DIV00022
13	Coude M 12L - M G3/8 conique/	Ölanschluss/	Oil connector/	Empalme/	Колено наружное коническо	HYD10305
14	Rondelle plate 10L NFE25513/(Ø10.5/27 ep 2)	Scheibe/	Washer/	Arandela/		RON01099
15	Vérin SE: 35 C: 110 FREINAGE/	Zylinder/	Cylinder/	Cilindro hidraulico/		VER03537
16	Corde polypropylene Ø 8/	Strick/	Rope/	Cuerda/		DIV00083
17	Adaptateur valve M 12L - M 12L/(pour valve freinage)	Ölanschluss/	Oil connector/	Empalme/		HYD10032
18	Coupleur femelle à bille VF8R/(valve de freinage)	Kuppler/	Coupler/	Cuerpo/	Муфта внутренняя, шарико	HYD10735

ROLLMOT/ROLLMAX 10m30

Planche N°9.1 : Essieux non freinés

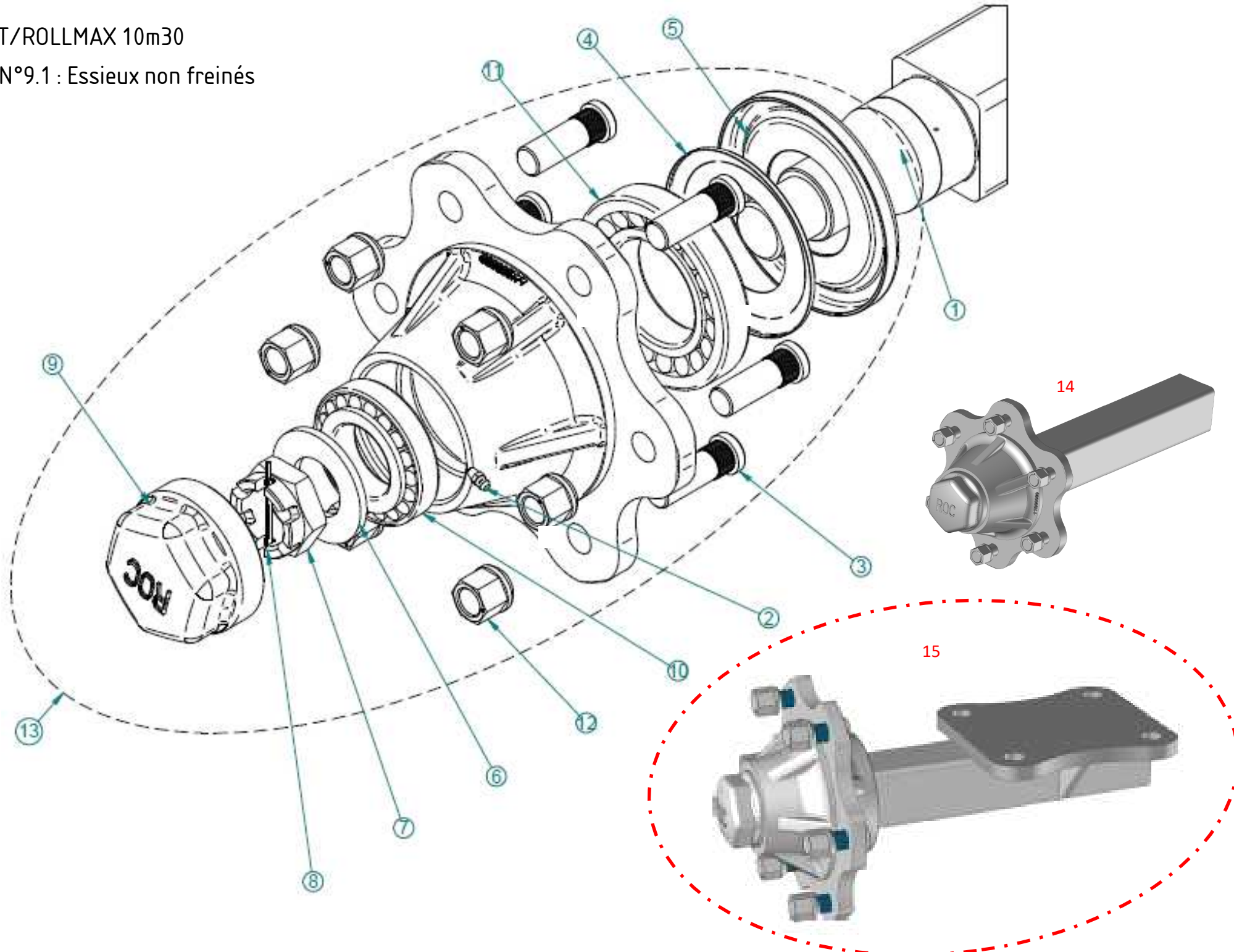

ROLLMOT/ ROLLMAX 10m30 (catalogue)

Rep.	Nom du produit	Beschreibung	Description	Designacion	Наименование	Code
2	Graisseur M 8 droit/	Schmiernippel/	Grease nipple/	Engrasador/	Масленка М 8 лрямая/	GRA08001
3	Goujon cranté M18 x 150 54/40/ZI, classe 10.9	Gewindebolzen/	Stud/	Esparrago roscado/	Шпилька М22x150/	ESS08021
4	Joint métallique 30213/	Metaldichtung/	A metal gasket/	Las juntas metálico/		ESS57011
5	Coupelle enveloppante 706X/65x131x2 (KTL)	konkav Unterlegscheibe/	dished washer/	arandela cóncava/		ESS57010
6	Rondelle plate 37x70x5/	Scheibe/	Washer/	Arandela/	Плоская шайба 37x70x5/	RON03702
7	Ecrou créneaux HK M36x2 H=25/	Mutter M36x2/	Nut M36x2/	Tuerca M36x2/	Корончатая гайка НК М36х	ECR36001
8	Goupille fendue 5 x 50 Zn/(DIN94 5x36Zn)	Stift 5x50/	Pin 5x50/	Pasador 5x50/	Разводной шплинт 5x 50 Zn	GOU05001
9	Bouchon de roue fileté Ø 86,5x/150	Stopfen/	Plug/	Tapòn/	Резьбовая заглушка колеса	ESS57002
10	Roulement rouleau conique/85/45 réf.30209	Lager/	Bearing/	Cujinete/	Подшипник 85/45 гйф.30209	RLT30209
11	Roulement rouleau conique/120/65 réf.30213	Lager/	Bearing/	Cujinete/	Подшипник 120/65 гйф.3021	RLT30213
12	Sachet écrous roue M18 pas 1.5/24/plat (Qantité x8)	Teil von dem Radachse/	Pant of wheel axle/	Parte del eje de rueda/		ESS56029
13	S/E Moyeu 706X JNI ROV/EC+GJS M18x1,5 LG.54/40	Nabe/	Hub/	Cubo/		ESS57013
14	Essieu c70-6 axes voie 440/non freiné	Radachse/	Wheel axle/	Eje/		ESS07009
15	Essieu ½ complet c70-6 axes/voie 440 pour ROLLMOT	Radachse/	Wheel axle/	Eje/		ESS07043

ROLLMOT/ROLLMAX 10m30

Planche N°9.2 : Essieux Freinés

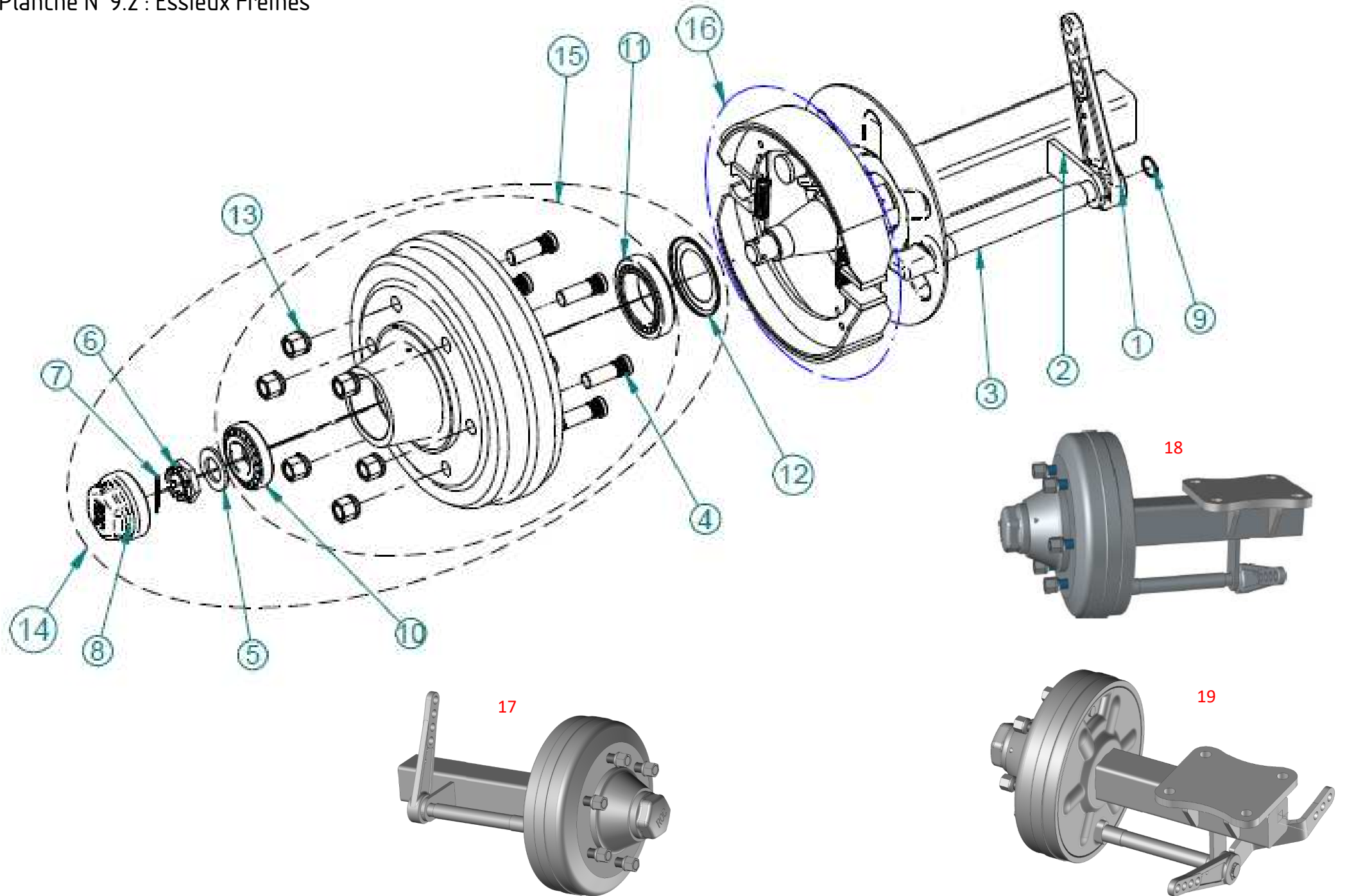

ROLLMOT/ ROLLMAX 10m30 (catalogue)

Rep.	Nom du produit	Beschreibung	Description	Designacion	Наименование	Code
1	Biellette 4 trous Ø24,5 (frein/300x60C) brochée	Schubstange/	Link/	Bieleta/		ESS56060
2	Support de came de frein 300x/60C lg 87 (essieu c 70)	Trag/	Support/	Soporte/		ESS57102
3	Came de frein 300x 60C/(lg sous tête à préciser) bielle	Bremsnocken/	Brake cam/	Leva del freno/		ESS56059
4	Goujon M18x150 lg54/39/	Gewindebolzen/	Stud/	Esparrago roscado/	Шпилька M18x150 дл.54/39	ESS56003
5	Rondelle plate 31x52x4/	Scheibe/	Washer/	Arandela/	Плоская шайба 31x52x4/	RON03101
6	Ecrou créneaux HK M30x200/	Mutter M30x200/	Nut M30x200/	Tuerca M30x200/	Корончатая гайка НК М30х	ECR30004
7	Goupille fendue 5 x 40 Zn/	Stift 5x40/	Pin 5x40/	Pasador 5x40/		GOU05000
8	Bouchon de roue fileté Ø 81,5x/1,5	Stopfen/	Plug/	Tapòn/		ESS56101
9	Circlips extérieur Ø 24/	Seegering/	Circlip/	Anillo/		CIR02400
10	Roulement rouleau conique/80/40 réf.30208	Lager/	Bearing/	Cujinete/	Конический подшипник 80/	RLT30208
11	Roulement rouleau conique/120/65 réf.30213	Lager/	Bearing/	Cujinete/	Подшипник 120/65 гйф.3021	RLT30213
12	Cache poussière 65x98 (013)/	Staubschutzhaube/	dust cover/	guardapolvo/		ESS57022
13	Ecrou de goujon M18x150/24 plats	Mutter/	Nut/	Tuerca/	Гайка шпильки M18x150 24	ESS56004
14	S/E Moyeu 706MF1 300x60C/Complet	Nabe/	Hub/	Cubo/		ESS57033
15	S/E Moyeu 706MF1 300x60C/+GJS+ECR+RLT	Nabe/	Hub/	Cubo/		ESS57034
16	Kit 2 Mâchoires frein 300x60C/+ ressorts	Gabel/	Yoke/	Horquilla/		ESS56061
17	Essieu ½ c70-6 axes voie 440//1 frein 300x60 lg came	Radachse/	Wheel axle/	Eje/		ESS07006
18	Essieu ½ c70-6 axes GA/voie 440 frein300x60	Radachse/	Wheel axle/	Eje/	Ось S c70-6 осей-дл.440/	ESS07044
18	Essieu ½ c70-6 axes DR/voie 440 frein300x60	Radachse/	Wheel axle/	Eje/	Ось S c70-6 осей-дл.440/	ESS07042
19	Essieu ½ c70-6 axes DR/voie 440 frein 300x60 BIELETTE BOOMERANG	Radachse/	Wheel axle/	Eje/		ESS07045
19	Essieu ½ c70-6 axes GA/voie 440 frein 300x60 BIELETTE BOOMERANG	Radachse/	Wheel axle/	Eje/		ESS07046

Planche N°9.3 : ROLLMOT / ROLLMAX
Jantes + Roues

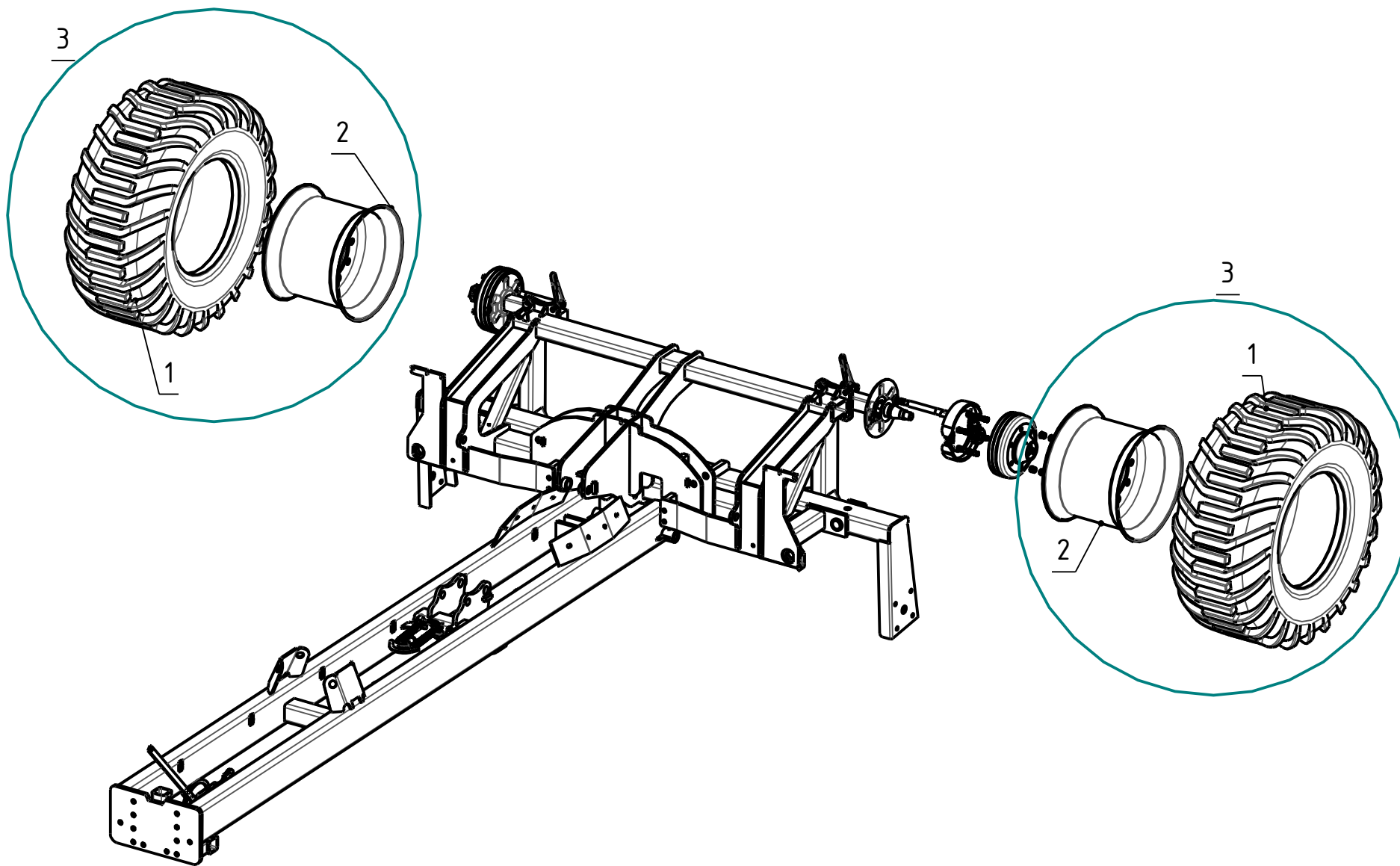

ROLLMOT/ROLLMAX 10m30 (catalogue)

Rep.	Nom du produit	Beschreibung	Description	Designacion	Наименование	Code
1	Pneu 15,0/55x17/	Reifen/	Tyre/	Neumatico/	Шина 15/55x17/	PNE01500
1	Pneu 400/60x15,5 145 A8/	Reifen/	Tyre/	Neumatico/	Шина 400/60x15,5/	PNE40000
2	Jante 15 x 17 - 6 trous/	Radfelge/	Wheel rim/	Llanta de rueda/	Диск колеса 15x17/6отв./	JAN01500
2	Jante 400/60x15,5 deport 40/(D ou G idem)	Radfelge/	Wheel rim/	Llanta de rueda/	Комплект дисков сларенны	JAN40001
3	Roue 15,0/55x17 TL 12 BKT/AW705 6/0 161x205	Rad/	Wheel/	Rueda/		RPN01500
3	Roue 400/60x15,5 droite BP/TL145A8 T404 6 trous, de Rad/		Wheel/	Rueda/	Колесо 400/60x15,5/14отв./	RPN40001
3	Roue 400/60x15,5 gauche BP/TL145A8 T404 6 trous, d Rad/		Wheel/	Rueda/	Колесо 400/60x15,5/14отв./	RPN40002

Planche N°10 : ROLLMOT / ROLLMAX
Bac à pierres

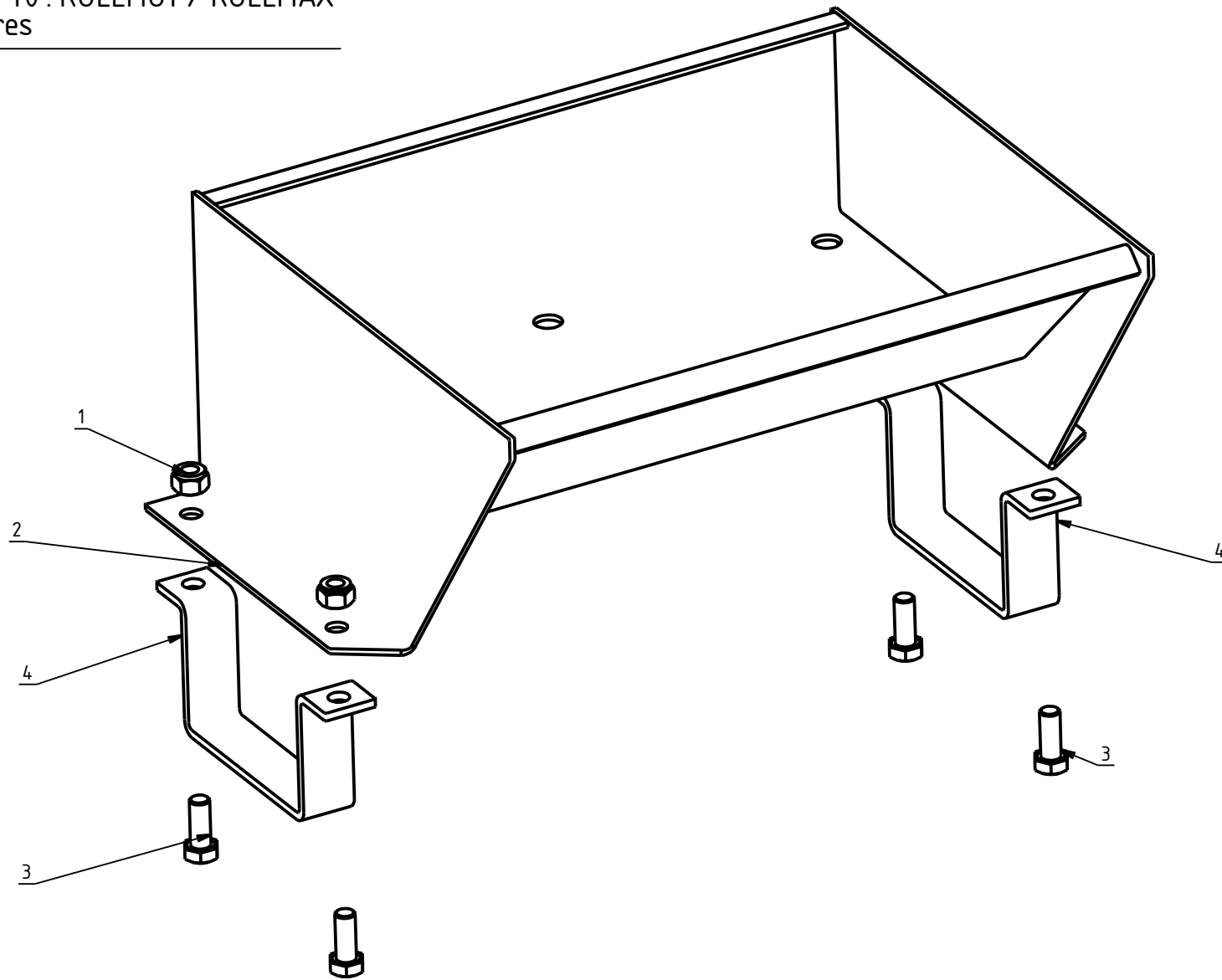

ROLLMOT/ROLLMAX 10m30 (catalogue)

Rep.	Nom du produit	Beschreibung	Description	Designacion	Наименование	Code
1	Ecrou nylstop M14 Zn/	Mutter M14/	Nut M14/	Tuerca M14/	Гайка nylstop M14 Zn/	ECR14002
2	Bac à pierres/	Behälter/	Tub/	Cubeta/		RAP01220
3	Vis T.H. 14x 35 8.8 brut/filetage total	Schraube/	Screw/	Tornillo/	Болт Т.Н. 14x 35 8.8 лолн	VIS14002
4	Bride de bac à pierres/	Bride/	Bridle/	Brida/	Фланец/	RAP01222

Planche N°11: ROLLMOT/ROLLMAX
Semoirs + Signalisation

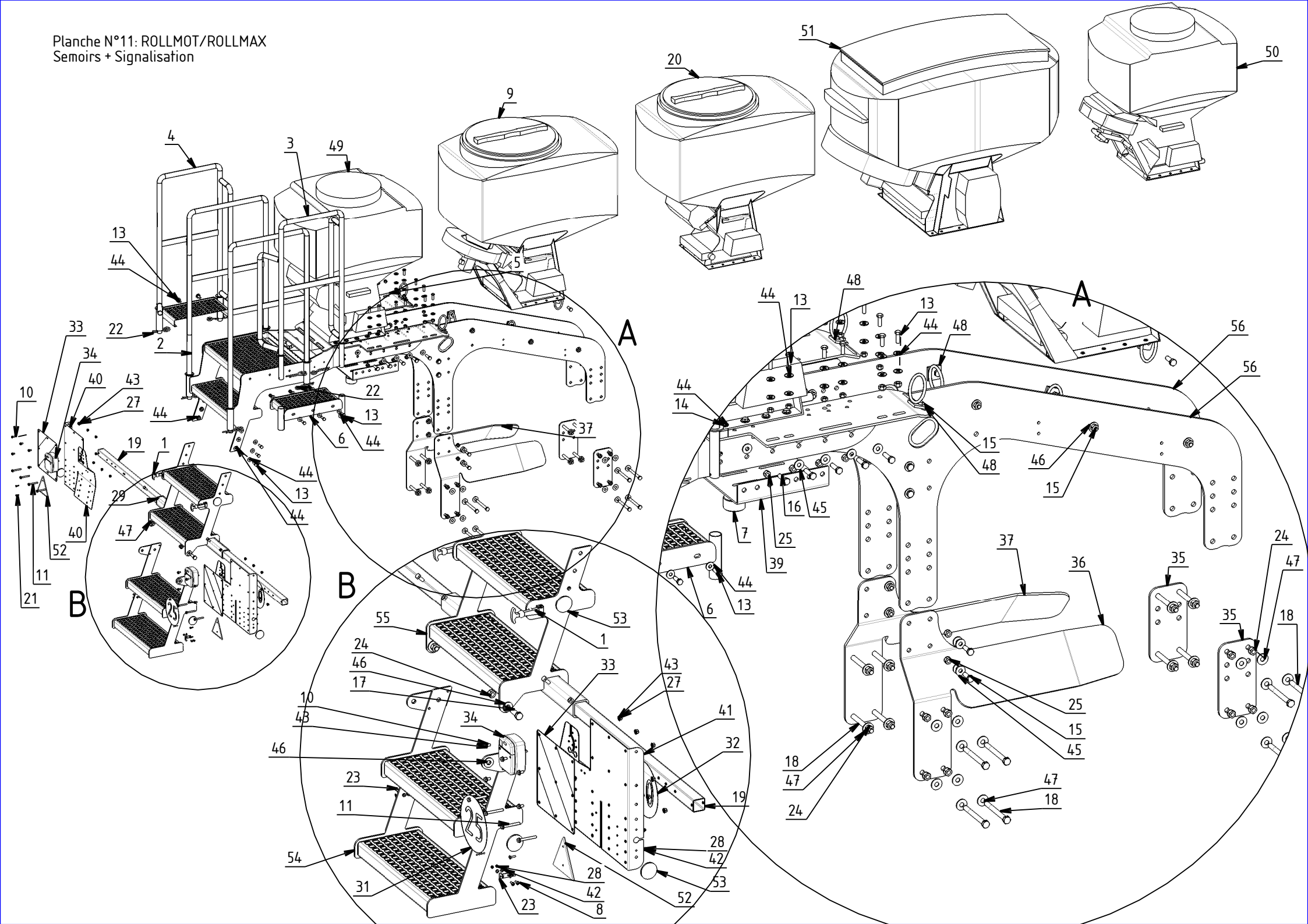

ROLLMOT/ROLLMAX 10m30 (catalogue)

Rep.	Nom du produit	Beschreibung	Description	Designacion	Наименование	Code
1	Fermeture caoutchouc lg 120CPL/	Klemmfinger mit handbetäti	Plant holder/	Pinza de cierre manual/		DIV00200
2	Rambarde DR ou GA - PS300/500/EA=580 Rollmot/R	Geländer/	Guard rail/	Barandilla/		RAP01508
3	Rambarde DR - PS800H M1/Rollmot/Rollmax	Geländer/	Guard rail/	Barandilla/		RAP01509
4	Rambarde GA - PS800H M1/Rollmot/Rollmax	Geländer/	Guard rail/	Barandilla/		RAP01510
5	Plateforme haute semoir APV/ROLLMOT ROLLMAX -	Plattform/	Platform/	Plataforma/		RAP01502
6	Rallonge passerelle/PS800H M1 Rollmot/Rollmax	Erweiterung/	extension/	extensión/		RAP01511
7	Support antivibrant/cylindrique Ø75 H40 M12x37	Stossdämpfer/	Shock absorber/	Amortiguador/	Антивибрационная цилиндр	SUP30500
8	Vis poelier M 5x16 Zn blanc/	Schraube 5x16/	Screw 5x16/	Tornillo 5x16/	Болт М 5x16 Zn/	VIS05012
9	Semoir PS 500 M2 ventilateur/hydraulique	Sämaschine/	seeder/	sembrador/		SEM00320
10	Vis T.H. 8x 16 8,8 Zn/filetage total	Schraube 8x16/	Screw 8x16/	Tornillo 8x16/	Винт Т.Н. 8x 16 8,8 Zn лол	VIS08027
11	Vis T.H. 8x 65 8,8 Zn/	Schraube/	Screw/	Tornillo/		VIS08041
12	Vis T.H. 10x 25 8.8 Zn/	Schraube/	Screw/	Tornillo/	Болт Т.Н.10x 25 8.8 Zn 2481	VIS10033
13	Vis T.H. 12x 35 8.8 Zn/filetage total	Schraube/	Screw/	Tornillo/	Болт Т.Н.12x 35 8.8 Zn лол	VIS12009
14	Vis T.H. 12x 45 8.8 Zn/	Schraube/	Screw/	Tornillo/		VIS12013
15	Vis T.H. 14x 40 8.8 Zn/	Schraube/	Screw/	Tornillo/	Винт Т.Н.14x 40 8.8 Zn/	VIS14006
16	Vis T.H. 14x 50 8,8 Zn/filetage total	Schraube 14x50/	Screw 14x50/	Tornillo 14x50/	Болт Т.Н.14x50 8,8/	VIS14044
17	Vis T.H. 16x 45 8.8 Zn/	Schraube/	Screw/	Tornillo/		VIS16006
18	Vis T.H. 16x150 8.8 Zn/	Schraube/	Screw/	Tornillo/		VIS16051
19	Tube support panneaux/réfléchissants lg 2800	Tube/	Tube/	Tubo/	Труба дл. 2800/	SIG10280
20	Semoir PS 500 M2 ventilateur/Electrique	Sämaschine/	seeder/	sembrador/		SEM00330
21	Vis poelier M 5x20 Zn blanc/	Schraube 5x20/	Screw 5x20/	Tornillo 5x20/	Болт М 5x20 Zn/	VIS05001
22	Goupille beta Ø6 double/boucle	Stift beta/	Pin beta/	Pasador beta/	Штифт beta Ш6/	GOU06013
23	Fermeture caoutchouc lg 120CPL/	Klemmfinger mit handbetäti	Plant holder/	Pinza de cierre manual/		DIV00200
24	Ecrou nylstop M16 Zn/	Mutter M16/	Nut M16/	Tuerca M16/	Гайка nylstop M16 Zn/	ECR16002
25	Ecrou nylstop M14 Zn/	Mutter M14/	Nut M14/	Tuerca M14/	Гайка nylstop M14 Zn/	ECR14002
26	Ecrou nylstop M12 Zn/DIN 985	Mutter M12/	Nut M12/	Tuerca M12/	Гайка nylstop M12 Zn DIN 9	ECR12002
27	Ecrou nylstop M 8 Zn/	Mutter M8/	Nut M8/	Tuerca M8/	Гайка М 8 Zn/	ECR08001

ROLLMOT/ROLLMAX 10m30 (catalogue)

Rep.	Nom du produit	Beschreibung	Description	Designacion	Наименование	Code
28	Ecrou nylstop M 5 Zn/	Mutter/	Nut/	Tuerca/	Гайка nylstop M5 Zn DIN 98	ECR05001
29	Ecrou H. M10 Zn/	Mutter M10/	Nut M10/	Tuerca M10/	Гайка H. M10 Zn/	ECR10001
31	Etiquette "25 km/h"/	Etikett/	Sticker/	Etiqueta/	Этикетка 25 км/ч/	ETQ00300
32	Etiquette "40 km/h"/	Etikett 40/	Sticker 40/	Etiqueta 40/		ETQ00302
33	Kit 2 panneaux 282x282 Droite//Gauche rouge-blanc +	Reflektierende Platten/	Reflective plates/	Placas reflexivas/	Комплект 2 панелей 423x28	KHR00909
34	Feux LED Homologués 2015/208/Lg alim 9m, Lg entre-	Lichtleitung/	Light circuit/	Circuito de alumbrado/		KIT00988
35	Contre plaque support plate-/forme semoir APV ROLL	Verspannung/	Sturdy rib/	Refuerzo/		RAP01505
36	Renfort support DR/semoir APV ROLLMOT 10m30 à 1	Verspannung/	Sturdy rib/	Refuerzo/		RAP01504
37	Renfort support GA/semoir APV ROLLMOT 10m30 à 1	Verspannung/	Sturdy rib/	Refuerzo/		RAP01512
39	Passe tuyaux support plate-/forme semoir APV ROLLM	Halter/	Bracket/	Soporte/		RAP01506
40	support panneau AR GA/UE 2019 (reglement 2015-208	Halter/	Holder/	Soporte/		KHR01001
41	support panneau AR DR/UE 2019 (reglement 2015-208	Halter/	Holder/	Soporte/		KHR01000
42	Rondelle plate 5,2x12x1 Zn/	Scheibe/	Washer/	Arandela/		RON00500
43	Rondelle plate 8,5x17x1,5/Zn	Scheibe/	Washer/	Arandela/		RON00801
44	Rondelle plate 12x30x3 Zn/	Scheibe/	Washer/	Arandela/	Плоская шайба 12x30x3/	RON01202
45	Rondelle plate 14x35x3 Zn/	Scheibe Ø14x35x3/	Washer Ø14x35x3/	Arandela Ø14x35x3/	Плоская шайба 14x35x3 Zn/	RON01404
46	Rondelle plate 17x32x3 Zn/	Scheibe/	Washer/	Arandela/	Плоская шайба 16x35x3 Zn/	RON01603
47	Rondelle plate 16x40x3 Zn/NFE25513	Scheibe/	Washer/	Arandela/		RON01609
48	Support canalisations semences/- Coudé	Trag/	Support/	Soporte/		SEM00210
49	Semoir PS 300 M1 ventilateur/électrique	Sämaschine/	seeder/	sembrador/		SEM00300
50	Semoir PS 300 M1 ventilateur/hydraulique	Sämaschine/	seeder/	sembrador/		SEM00310
51	Semoir PS 800 M1 ventilateur/hydraulique	Sämaschine/	seeder/	sembrador/		SEM00800
52	Triangle (catadioptré)/	Dreieck/	Triangle/	Triángulo/		SIG00102
53	Catadioptré orange Ø60 adhésif/	Rückstrahler/	Reflector/	Reflector/		SIG00103
54	Escalier mobile 2M semoir APV/ROLLMOT ROLLMAX	Trappe/	Staircase/	Escalera/		RAP01500
55	Escalier fixe semoir APV/ROLLMOT ROLLMAX	Trappe/	Staircase/	Escalera/		RAP01501
56	Bras de déport haut DR & GA/ROLLMOT ROLLMAX	Links / Recht Kurbelarm/	Left / Right crank/	Brazo derecha / izquierda/		RAP01503

Planche N°12: ROLLMOT/ROLLMAX
Signalisation

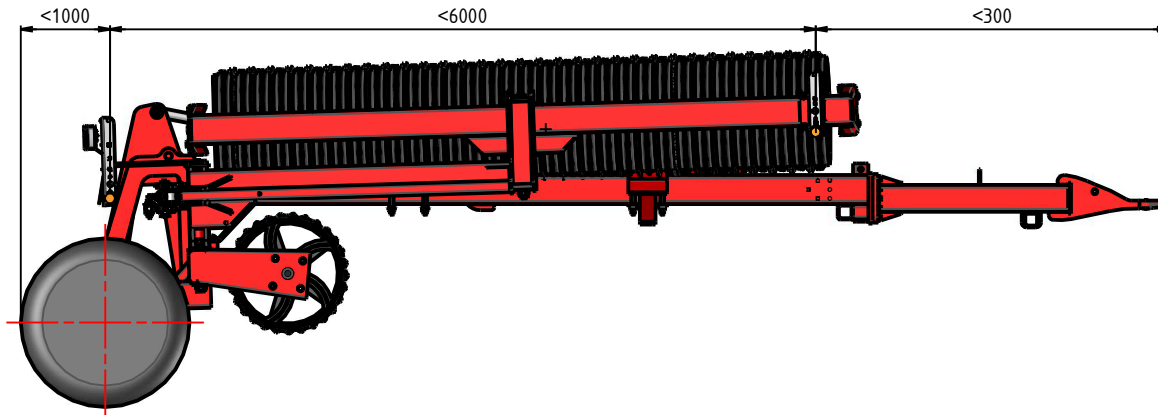
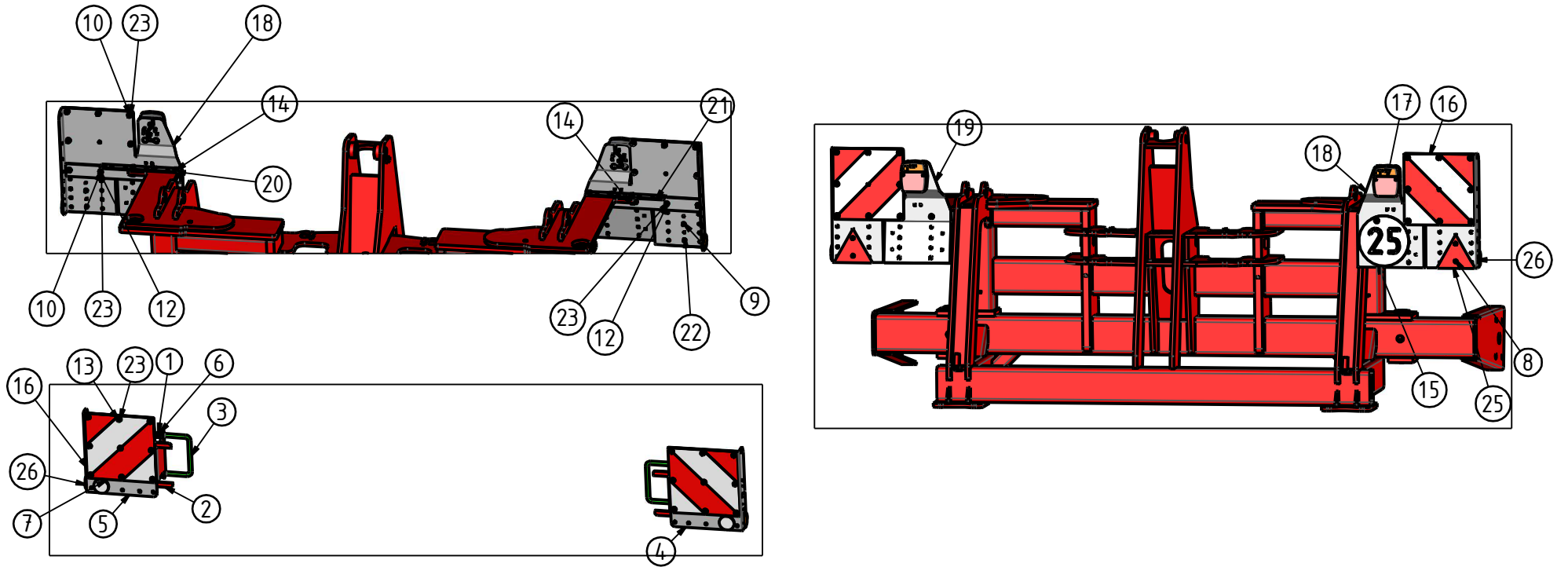

ROLLMOT/ROLLMAX 10m30 (catalogue)

Rep.	Nom du produit	Beschreibung	Description	Designacion	Наименование	Code
1	Ecrou nylstop M14 Zn/	Mutter M14/	Nut M14/	Tuerca M14/	Гайка nylstop M14 Zn/	ECR14002
2	support signalisation AV/rollmot-max reglement 2015-2	Trag/	Support/	Soporte/		KHR01011
3	Etrier Ø14 x152x 140/50 acier/C35, chanfreiné, TTh+R	U-Bolzen/	U-Bolt/	Brida en U/		ETR14015
4	support panneau AV GA/UE 2019 (reglement 2015-208	Halter/	Holder/	Soporte/		KHR01002
5	support panneau AV DR/UE 2019 (reglement 2015-208	Halter/	Holder/	Soporte/		KHR01003
6	Rondelle plate 14x35x3 Zn/	Scheibe Ø14x35x3/	Washer Ø14x35x3/	Arandela Ø14x35x3/	Плоская шайба 14x35x3 Zn/	RON01404
7	Catadioptr blanc Ø54 adhésif/	Rückstrahler/	Reflector/	Reflector/		SIG00100
8	Vis poelier M 5x20 Zn blanc/	Schraube 5x20/	Screw 5x20/	Tornillo 5x20/	Болт М 5x20 Zn/	VIS05001
9	Ecrou nylstop M 5 Zn/	Mutter/	Nut/	Tuerca/	Гайка nylstop M5 Zn DIN 98	ECR05001
10	Ecrou nylstop M 8 Zn/	Mutter M8/	Nut M8/	Tuerca M8/	Гайка М 8 Zn/	ECR08001
11	Ecrou nylstop M10 Zn/DIN 985 0871	Mutter M10/	Nut M10/	Tuerca M10/	Гайка nylstop M10 Zn/	ECR10002
12	Vis T.H. 8x 25 8,8 Zn/filetage total	Schraube/	Screw/	Tornillo/	Болт Т.Н. 8x25 8.8 zn/	VIS08028
13	Vis T.H. 8x 20 8.8 Zn/DIN 933	Schraube 8x20/	Screw 8x20/	Tornillo 8x20/	Болт Т.Н. 8x 20 8.8 Zn DIN	VIS08005
14	Vis T.H. 10x 35 8.8 Zn/filetage total	Schraube/	Screw/	Tornillo/	Винт Т.Н. 10x 35 8.8 Zn/	VIS10026
15	Etiquette "25 km/h"/	Etikett/	Sticker/	Etiqueta/	Этикетка 25 км/ч/	ETQ00300
16	Kit 2 panneaux 282x282 Droite//Gauche rouge-blanc +	Reflektierende Platten/	Reflective plates/	Placas reflexivas/	Комплект 2 панелей 423x28	KHR00909
17	Feux LED Homologués 2015/208/Lg alim 9m, Lg entre-	Lichtleitung/	Light circuit/	Circuito de alumbrado/		KIT00988
18	support panneau AR DR/UE 2019 (reglement 2015-208	Halter/	Holder/	Soporte/		KHR01000
19	support panneau AR GA/UE 2019 (reglement 2015-208	Halter/	Holder/	Soporte/		KHR01001
20	support panneau DR rollmot-max/UE 2019 (reglement	Halter/	Holder/	Soporte/		KHR01004
21	support panneau GA rollmot-max/UE 2019 (reglement	Halter/	Holder/	Soporte/		KHR01005
22	Rondelle plate 5,2x12x1 Zn/	Scheibe/	Washer/	Arandela/		RON00500
23	Rondelle plate 8,5x17x1,5/Zn	Scheibe/	Washer/	Arandela/		RON00801
24	Rondelle plate 10L NFE25513/(Ø10.5/27 ep 2)	Scheibe/	Washer/	Arandela/		RON01099
25	Triangle (catadioptr)/	Dreieck/	Triangle/	Triángulo/		SIG00102
26	Catadioptr orange Ø60 adhésif/	Rückstrahler/	Reflector/	Reflector/		SIG00103

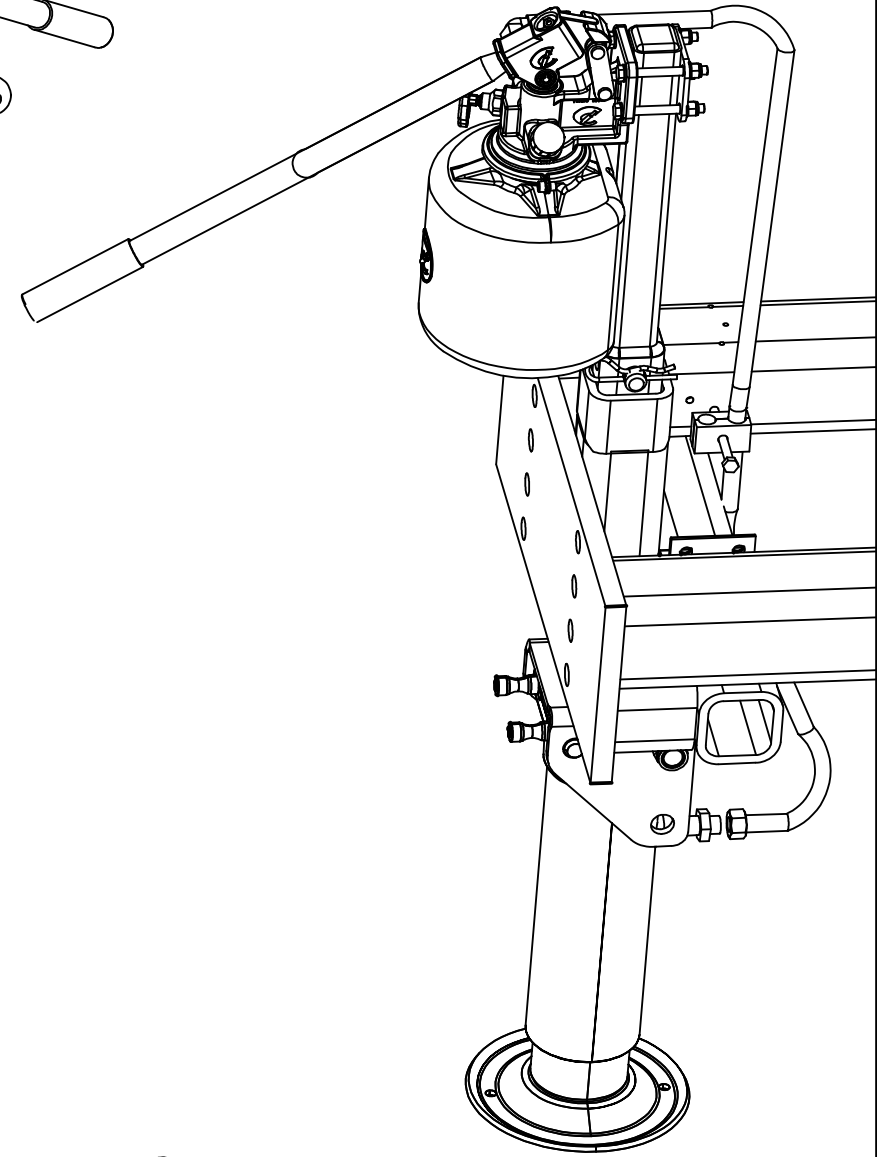
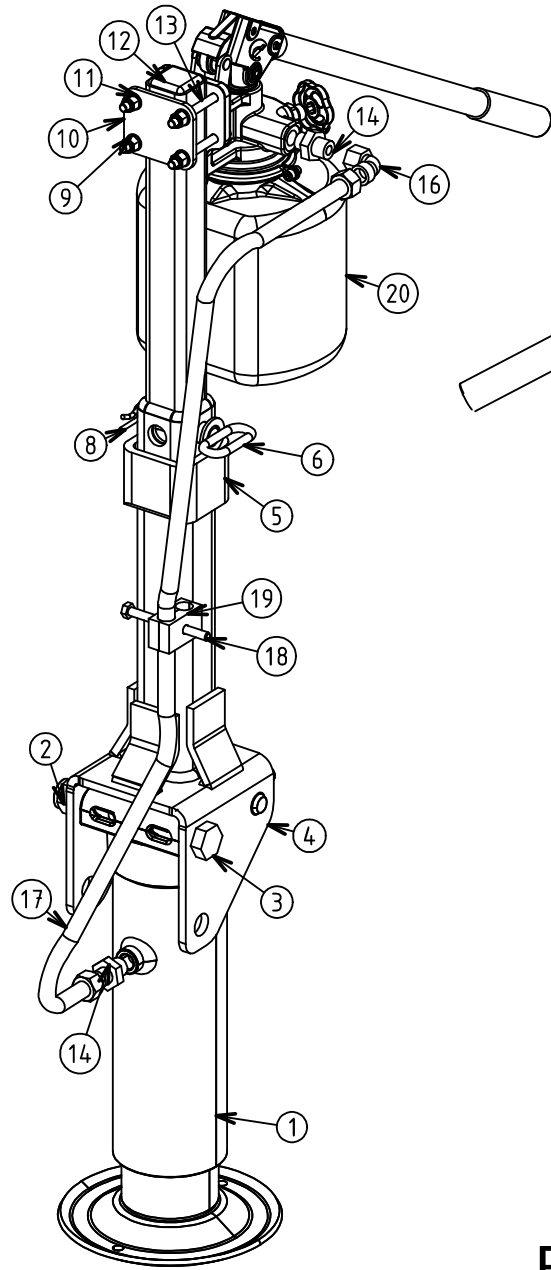
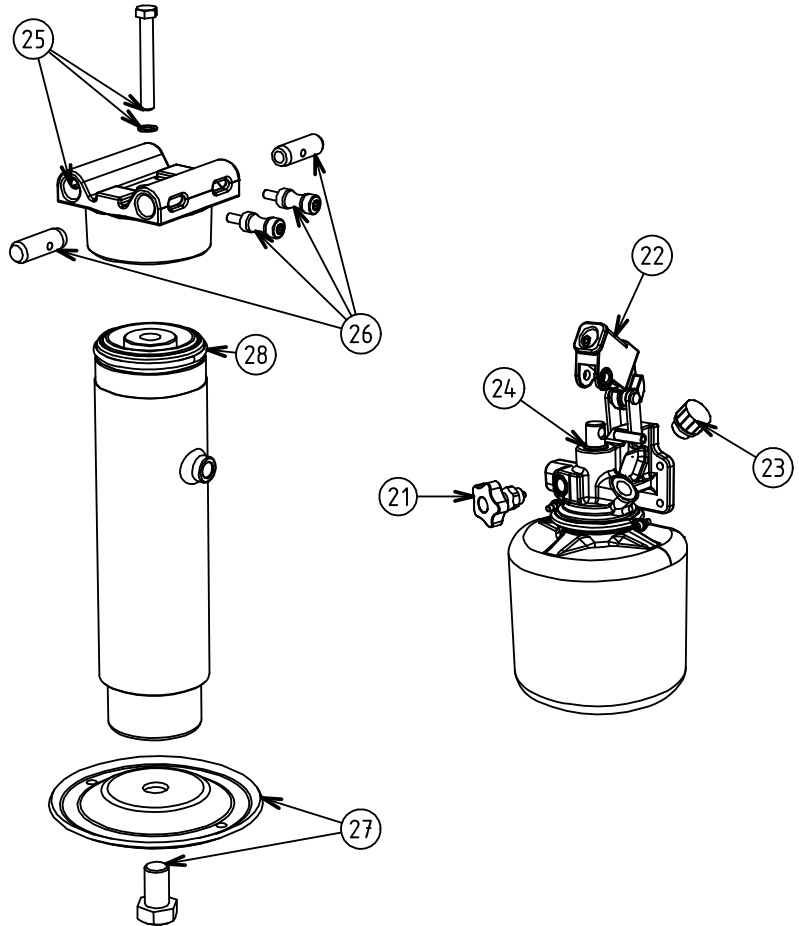
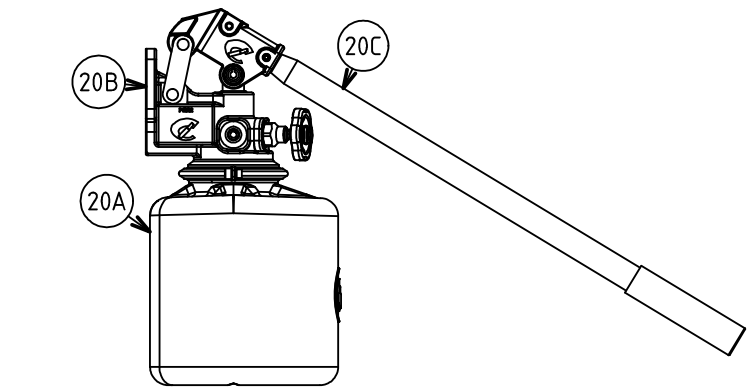

ROLLMAX
N° 13

ROLLMOT/ROLLMAX 10m30 (catalogue)

Rep.	Nom du produit	Beschreibung	Description	Designacion	Наименование	Code
1	Vérin SE: 91 C: 230 béquille/hydraulique	Zylinder/	Cylinder/	Cilindro hidraulico/		VER09100
2	Ecrou nylstop M20 Zn/DIN 985	Mutter M20/	Nut M20/	Tuerca M20/	Гайка nylstop M20 Zn DIN 9	ECR20003
3	Vis T.H. 20x160 8.8 Zn/	Schraube 20x160/	Screw 20x160/	Tornillo 20x160/	Винт Т.Н.20x160 8.8 Zn/	VIS20042
4	Support bequille hydraulique/manuelle pour ROLLMOT	Halter für die hyd. Stütze/	Bracket/	Soporte/		RAP01371
5	Entretoise tube carré 80 lg 60/pompe hydraulique man	Distanzring/	Spacer/	Arandela distanciadora/		RAP01373
6	Broche Ø20x 85 avec maillon/	Spindel Ø20x75/	Pin Ø20x75/	Pasador Ø20x75/	Штырь Ш20x75/	BRO02003
8	Goupille beta Ø4/	Stift beta Ø4/	Pin beta Ø4/	Pasador beta Ø4/	Штифт beta Ш4/	GOU04000
9	Ecrou nylstop M 8 Zn/	Mutter M8/	Nut M8/	Tuerca M8/	Гайка М 8 Zn/	ECR08001
10	Platine 4 trous/pompe hydraulique	Platte/	Plate/	Placa/		RAP01702
11	Rondelle plate 8,5x17x1,5/Zn	Scheibe/	Washer/	Arandela/		RON00801
12	Bouchon tube 40x40x1,0-2,0/plastique	Stopfen/	Plug/	Tapòn/		BOU10019
13	Vis T.H. 8x 80 8.8 Zn/	Schraube/	Screw/	Tornillo/	Болт Т.Н. 8x 80 8.8 Zn/	VIS08034
14	Union M 12L - M G3/8 cyl/	Ölanschluss/	Oil connector/	Empalme/	Соединение М 12L - М 3/	HYD10076
16	Coude tournant M 12L - F 12L/	Ölanschluss/	Oil connector/	Empalme/	Колено М 12L - F 12L/	HYD10452
17	Flexible FF 12L lg 1200/TD2C8 EFR12L-EFR12L	Schlauch/	Hydraulic hose/	Tuberia/	Шланг FF TD2C8 EFR12L-E	FFD01208
18	Vis T.H. 8x100 Zn DIN 931/	Schraube/	Screw/	Tornillo/	Болт Т.Н. 8x 100 8.8 /	VIS08045
19	Fixation 2 flexibles Ø16/partie plastique	Flexible Befestigung Ø16/	Flexible mounting Ø16/	Montaje flexible Ø16/		DIV00008
21	Robinet pompe à main/	Hahn/	Tap/	Espita/		HYD10954
22	Manette alu pompe à main/	Regler/	Controller/	Controlador/		HYD10955
23	Bouchon reniflard 1/2/	Stopfen/	Plug/	Tapòn/		HYD10956
24	Pochette de joints pompe à/main 20 ECO	Dichtungen/	Seal kit/	Juntas/		HYD10957
25	Kit fond béquille pompe à main/	Zylinderboden/	Cylinder bottom/	Fondo del cilindro/		HYD10958
26	Kit verrouillage automatique/bequille hydraulique	Verriegelunsatz/	Kit locking/	Equipo bloqueo/	Комплект фиксаторов/Z6	VER00021
27	Kit semelle béquille pompe à/main	Ständer/	Stand/	Soporte/		HYD10959
28	Pochette de joints béquille/Ø91 C230	Dichtungen/	Seal kit/	Juntas/		HYD10961
20A	Réservoir plastique pour pompe/hydraulique à main	Fass/	Tank/	Cuba/		HYD10952
20B	Système de pompe pour pompe/hydraulique à main	Pumpe/	Pump/	Bomba/		HYD10951

ROLLMOT/ROLLMAX 10m30 (catalogue)

Rep.	Nom du produit	Beschreibung	Description	Designacion	Наименование	Code
20C	Manivelle pour pompe hydrauliq/à main	Hebel/	Lever/	Palanca/		HYD10953

ROLLMOT - ROLLMAX 10m30

Planche N°14 : Montage compteur d'hectares sur section

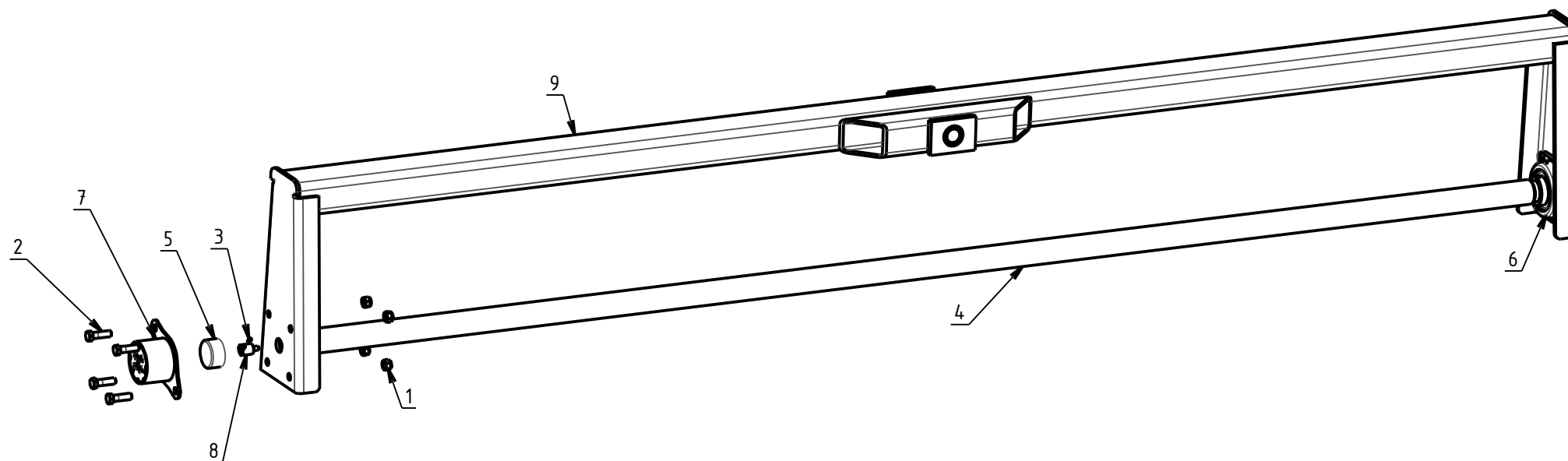

	REPERE 9 : SECTION		REPERE 4 : ARBRE
	Rouleaux lisses Ø610 et Roues fontes	Rouleaux lisses Ø710 et Ø730	
10m30	SEC00066	SEC00076	ARB07093

ROLLMOT/ROLLMAX 10m30 (catalogue)

Rep.	Nom du produit	Beschreibung	Description	Designacion	Наименование	Code
1	Ecrou nylstop M18 Zn/	Mutter M18/	Nut M18/	Tuerca M18/	Гайка nylstop M18 Zn/	ECR18002
2	Vis T.H. 18x 60 8.8 Zn/Classe 8,8 DIN931	Schraube 18x60/	Screw 18x60/	Tornillo 18x60/	Болт Т.Н.18x 60 8.8 Zn/	VIS18003
3	Vis T.H.C. 8x16 8.8 brut b.poi/	Schraube 8x16/	Screw 8x16/	Tornillo 8x16/		VIS08014
4	Arbre Ø 70 lg 4180 (Etiré A60)/section rollmot/rollmax 1	Scheiben Welle/	Disc shaft/	Arbol de disco/		ARB07093
5	Compteur linéaire nu/	Begegnen/	Counter/	Contrarrestar/		DIV00051
6	Palier UCF 212 complet/	Lager UCF 212/	Bearing UCF 212/	Cojinete UCF 212/	Подшипник в сборе UCF 21	PAL06000
6	Palier UCF 212 complet graissé/à vie (sans entretien)	Lager/	Bearing/	Cojinete/		PAL06002
7	Support de compteur linéaire/ROLLMOT rouleau pour					RAP00050
8	Embout entretoise (compteur/linéaire)	Verspannen/	Brace/	Prepararse/		RAP01250
9	Section latérale Rollmax 10M30/tube lg 4200	Halter/	Bracket/	Soporte/		SEC00066
9	Section latérale Ø710 & Ø730/Rollmax 10m30, tube lg					SEC00076